

WALKER ART CENTER

Within the City: Phenomena of Relations

Author(s): Steven Holl

Source: *Design Quarterly*, No. 139, Within the City: Phenomena of Relations (1988), pp. 1-30

Published by: [Walker Art Center](#)

Stable URL: <http://www.jstor.org/stable/4091209>

Accessed: 28-12-2015 21:46 UTC

Your use of the JSTOR archive indicates your acceptance of the Terms & Conditions of Use, available at <http://www.jstor.org/page/info/about/policies/terms.jsp>

JSTOR is a not-for-profit service that helps scholars, researchers, and students discover, use, and build upon a wide range of content in a trusted digital archive. We use information technology and tools to increase productivity and facilitate new forms of scholarship. For more information about JSTOR, please contact support@jstor.org.



Walker Art Center is collaborating with JSTOR to digitize, preserve and extend access to *Design Quarterly*.

<http://www.jstor.org>

Within The City

Phenomena of Relations

Steven Holl

Steven Holl, professor of architecture, Columbia University Graduate School of Architecture and Planning, and a practicing architect in New York City, has, for a number of years, been exploring ideas about perception that could greatly increase our understanding of the built environment. In this issue of *Design Quarterly*, Holl's philosophical explication is followed by his visionary proposal for the Porta Vittoria section of Milan. In this work, physical examples are delineated that affirm the suppositions expressed in his essay.

Holl acknowledges the influence of the German philosopher Edmund Husserl (1859–1938), founder of phenomenology, a movement in which the study of consciousness is designed to reveal the structure of experience, free of assumptions or preconceptions. Following Husserl's theories, Holl pursues a direct

investigation of the urban environment. In it he deals with pure data, with the essence of things felt, seen, experienced. In his emphasis on the sensory, he rejects approaches to the design of cities that use typologies or historicism as conceptual points of departure. While using typology and history as tools in the planning process, Holl believes that those methods, together with the traditional means of depicting them (from plan to elevation to perspective view) severely limit the comprehension of three-dimensional space. Instead, he is concerned with depicting the perceptions of pedestrians moving through the multi-layered vertical and horizontal spaces of the city; thus he reverses the drawing process, projecting from perspectival space backward into plan.

In the proposal for Milan, Holl examines an urban sector on the periphery of the city. In this visionary project he raises a number of issues with broad implications for today's cities, and aspects of his solution for the Porta Vittoria might be applied equally well to the edges of many large European and American cities in which urban sprawl peters out into

an undefined interface with the countryside. For Milan, for example, Holl proposes a new, dense outer ring, which would be somewhat analogous in its definition of the urban edge to Europe's ancient city walls.

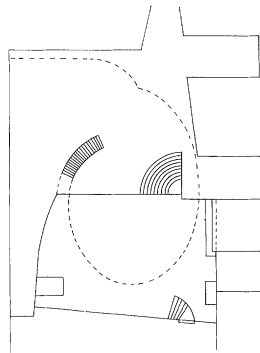
In his work, Holl creates form out of the direct experience of place. His is an architecture that could breathe new life into long neglected areas. What is clear in both the abstract and specific examples he cites is that Holl's experiential approach to architecture is essentially a romantic, humanistic one which focuses on our responses to the play of light and shadow on stone, to the movement of clouds through the night sky, and to the shifting planes of tall buildings seen as we move through the complex spaces of our cities.

MSF

Contents

5	Introduction	Space/Parallax/Perspective
		Semi-Automatic Programming
		Correlational Charts
		Matter/Tactility

20	Case Study	Porta Vittoria, Milan
----	------------	-----------------------



+

*The beginning drifts off,
the end vanishes.
There is neither start nor finish;
I am in the pause,
I neither end nor begin,
what I say...
the city in its circular fever
repeats and repeats.
Octavio Paz
In the middle of this phrase . . .*

New York City, 4 October 1987, 10 pm:

Walking down Second Avenue, I looked up astonished by a huge projection of white light. Cast onto the underside of a low cloud canopy over the city, the luminous parallelogram hovered directly above a skyscraper on 53rd Street. The frozen plane of white light defined a space between the bottom of the clouds and the building tops of the city. Suddenly a lower flying puff of clouds blew through this space, casting a free-form shadow across the white parallelogram.

The new urban space of this incident is only one among a phenomena of relations. Time, matter, space and light intermesh with the activities of a modern city forcing us to reconsider assumptions of urban planning.

Large modern cities characteristically are composed of isolated buildings enveloped in residual space. To reorder and create urban space, we must go beyond maximizing floor-area ratios or building on the lost lines of a city grid. Planimetric organization is insufficient in a city of tall buildings. Spatial perception and development in an urban setting require a three-dimensional, sectional approach that gives primary importance to the views of perambulating residents who traverse shifting ground planes, experiencing the city from multiple frames of reference. In this way, new volumetric spatial compositions can be projected, even if the current

political-economic hegemony of land speculation forestalls the search for a broader view.

The underdeveloped periphery of the center city can provide sites for the synthesis of these new spatial compositions. Between the center city and the countryside an intensified urban realm will spring up, a coherent mediator between the extremes of the metropolis and the agrarian plain.

Indiscriminate consumption by speculative development systematically defaces the landscapes of Europe and America. Not dense enough to be urban, not open enough to preserve the rural, sprawl conflates city and landscape into a thin homogeneity. Yet what remains of the wilderness must be preserved; agrarian landholders should be aided in their efforts to resist the petty encroachment of speculators. In the middle zone between landscape and city, there is hope for a new synthesis of urban life and urban form.

Intensity of experience in the city is equivalent to serenity and silence in a forest. But urban vitality depends on programmatic and spatial intensification. Programmatic consciousness, essential to spatial composition, is crucial to the quality of urban life. New programs and new modes of organization inevitable in an evolving societal structure must find an equivalent substantiality in urban form. Urban space approached from the simultaneous interaction of program, section, and material interrelates to form a psychological field. From this standpoint, the creation of urban space is a philosophical reflection.

The wordless silence of architectural and urban form has a philosophical equivalent in phenomenology. Resisting the language-based approach of the deconstructivists, its focus is on the experiential. Perception and the senses are intertwined with the material, space and light of urban form.

“Space/Parallax/Perspective” discusses motives for the conception of urban space through perspective and the overlapping of spatial and perceptual fields.

“Semi-Automatic Programming” attempts to speculate on the range of programs that could inhabit a projected urban field.

“Correlational Charts” diagrams a range of possible urban building sections. These are charted as a form of sectional investigation, for further exploration. Diverse relationships of section here suggest equally diverse relationships of program.

“Matter/Tactility” brings the attitude of relationships down to the scale of materials and construction. Moving from the macro: urban space, to the micro: the construction detail; we have jumped over the scale in which architectural order is clearly set, i.e., the individual building. Thus the title *Phenomena of Relations* characterizes this study as thoughts that hover around the edges of architecture; thoughts that need the precision of an architectural idea for activation.

A test of these ideas is seen in a project conceived for the Porta Vittoria sector on the periphery of Milan. Initiated as part of the XVII Triennale of Milan, it illustrates a specific investigation of an area on the perimeter of that city.

Space/Parallax/Perspective

What is taken into consideration by the perceiver in studying the spatial field between buildings? The individual building does not monopolize one's thoughts. Concentration is on the relationships between buildings: the terrain, the sky, light, axes of movement.

In a four or five story city, urban space can be envisioned at the ground plane in a simple "figure-ground" plan. Urban space is reconciled to one horizontal plane (x-y space, fig. 1).

At a metropolitan scale, sections of buildings are many times greater than the dimensions of plans. Urban space is formed by vertical groupings, terrestrial shifts, elongated slots of light, bridges and vertical penetrations of a fixed horizontal.

Urban space has a horizontal dimension transformed by vertical relationships. The vertical ("z" dimension) is equal to or more important than the horizontal. This perpendicular spatial order is amplified by a range of station points from various levels of the ground plane (fig. 2). From the upper floors of a tower, a roof terrace, a subway platform or an underpass, urban perspective in the "z" dimension is experienced on a shifting ground plane (fig. 3).

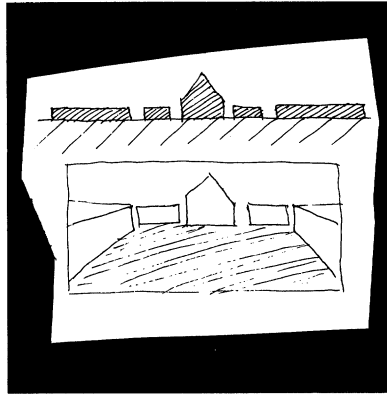


fig. 1

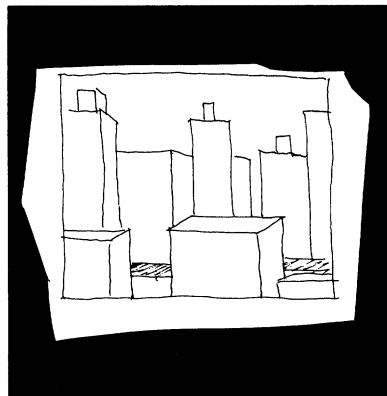


fig. 2

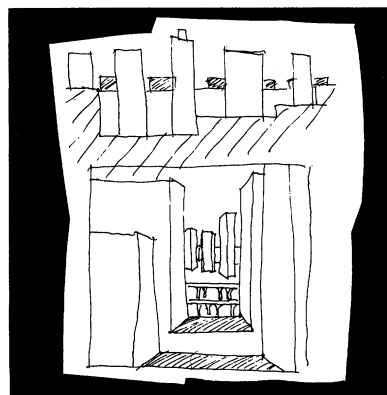
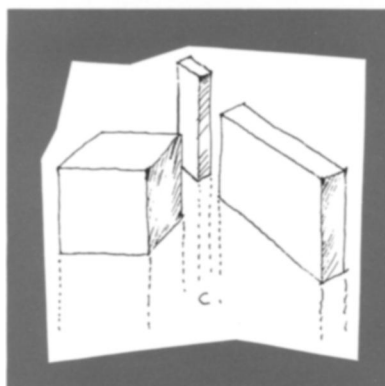
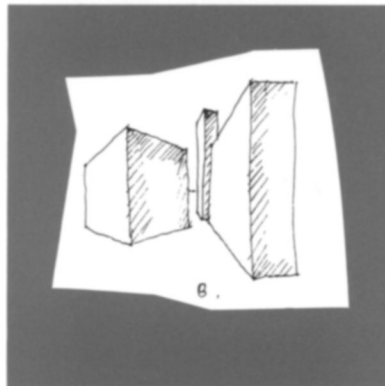
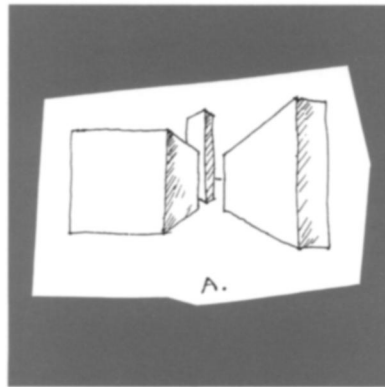
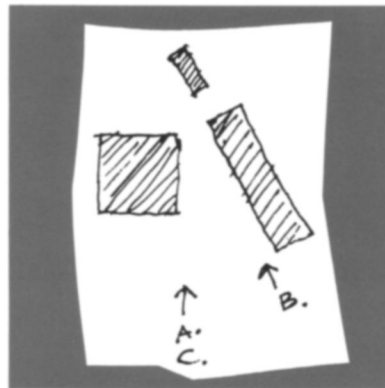


fig. 3

A and B, parallax

C, vertical shift



For a building to be motionless is the exception: our pleasure comes from moving about so as to make the building move in turn, while we enjoy all these combinations of its parts. As they vary; the column turns, depths recede, galleries glide: a thousand visions escape. . .

Paul Valéry
The Method of Leonardo

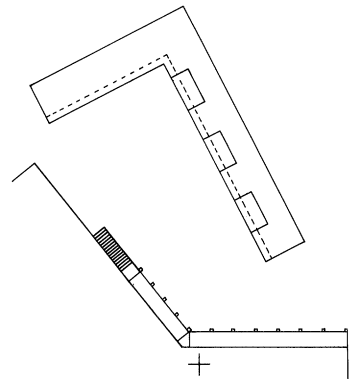
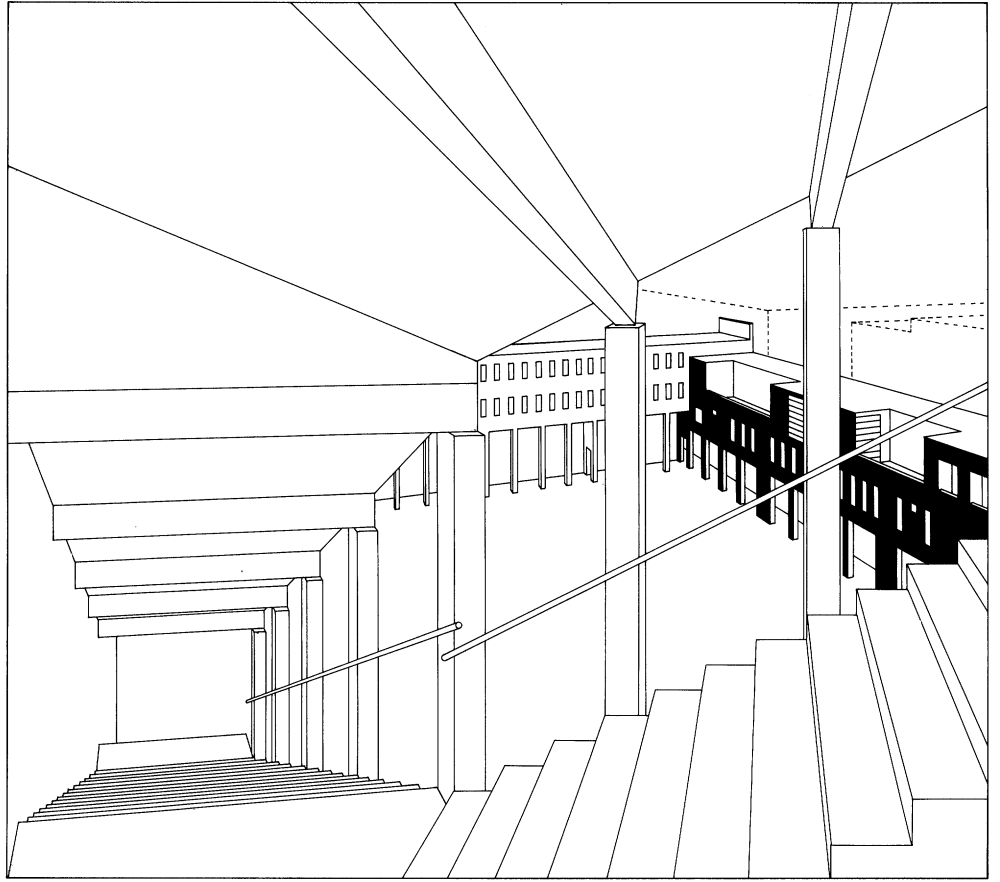
The experience of parallax—the change in the arrangement of surfaces defining space due to the change in position of a viewer—is transformed when movement axes leave the horizontal dimension. Vertical or oblique directions of movement through urban space multiply its experience. Spatial definition is ordered by angles of perception.

The edges, contours and surfaces of the structures that define urban spaces (redefined in parallax) must be considered in terms of the phenomenon of light. Here the idea of “facade” is too limiting. The experience of curved urban space generated by the slight rotation of individual planar facades is inseparable from the parabola of sunlight on its boundary. The movement of sunlight exerts relational forces on spatial definition that engage the body of a stationary building. Forces of sun, shadow and the reflectivity of materials interact.

The definition of city spaces at night depends on ellipses of projected light, glowing glass facades, and the transformations induced by mists and rain. A dense complex of blocks cut by a canyon street by day is redefined by night as shimmering prisms of light in a chiaroscuro of shadows. There are astonishing effects of vapors of fog at night when clouds of white light surround the tops of lighted towers, or golden gauzelike ribbons radiate into the night sky. Beyond drawing-board geometry, the actual spatial definitions of the city are interlocked in a web of relationships with movement, parallax and light.

Note: Black asphalt disappears under a white blanket.

An even glow at night brightens street spaces and courts. Noise is dampened to a whisper, broken only by the occasional ringing of a tire chain. Sound, light, and city space are phenomenally changed. Every snowflake takes a different form.



*Tilting back the head,
twisting the body, closing
one eye, stepping forward*

The problem of proposing urban space for a metropolitan sector whose program elements, architectural parts and social aspects are as yet unknown (and may always be in some state of flux) leads us to propose beginning from a perspectival experience of bounded space. The distribution of elements in a field with a sense of enclosure is imagined from the point of view of the perceiver. Oblique vertical or horizontal axes of movement alter this field of view as it overlaps with other fields. Instead of a priori plans projected later into perspective drawings, perspective views are made and cast backwards into plan fragments (fig. 4). A point of view, a point of experience of the urban field, is reconciled to movements of the body and changes of perception.

Potential alignments, partial exposures, and occultation of suggestive elements are all implied in a perspective view. Here the appetite of the field of vision invites the perceiver to invent. The next perspective view is provoked by the preceding view; spatial perspective drawings are not so much pictorial as they are indicative of a route complete with parallax. Consider an actual experience in a modern city: rising from a subway through a cavity to an unenclosed surface, the dominant view may continue up a tower; the head tilts back, one steps forward and up, the sense of space cannot be captured in a plan drawing. From a fixed position, sitting on the tenth floor looking out over a space above four story buildings surrounded by a twenty story set of blank party walls, one is unaware of the plan dimension, or the street space. An invigorating view of the contained urban space high above the street between urban blocks is animated by shifting strips of sunlight or birds flying daredevil between oblique gaps in buildings.

Envisioning urban space in perspectival views assumes a perceiver inserted into a condition meant to suggest and involve the imagination in envisioning what lies beyond. The point of view of the perceiver in an open field is not fixed. The perceiver has the authority to re-center, to isolate his or her own vision within the organization planned and expected. Rather than the establishment of a single center with a symmetrical hierarchy (as in fifteenth-century Europe), or reconciliation to the lack of any focus in a chaos of “decentering” (today’s deconstructivists), a re-centering allows for projection from a center in each individual. There are multiple centers and multiple viewpoints in the urban field. A city sector is not made for a mass of 10,000; it is made for 10,000 individual souls. Each has the capacity to manifest a spirit and in turn animate the psychological field of urban space.

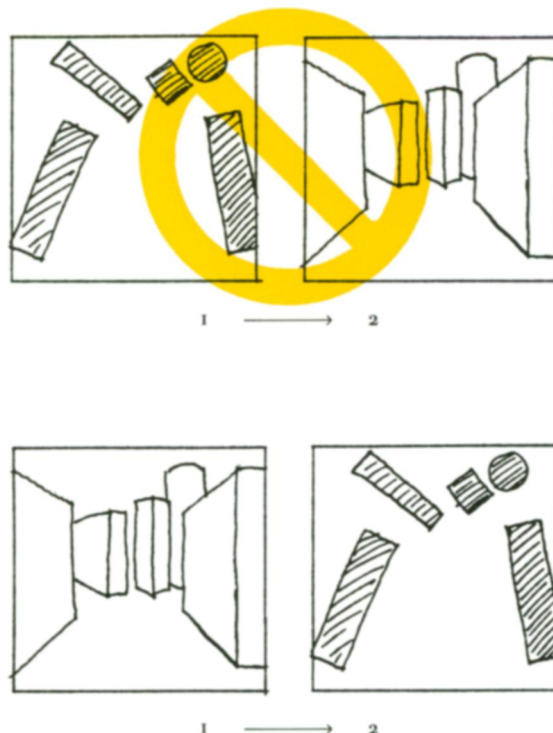
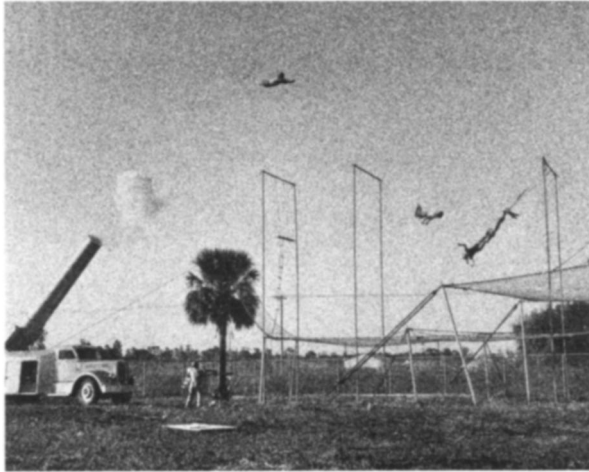


fig. 4



Transferral across fields



*Program = natural
phenomena + evidence
of causes + suspension*



Rightful autonomy



*The world's largest frying
pan (Central Maine Egg
Festival)*

Semi-Automatic Programming

Modern metropolitan life is characterized by programmatic fluctuation: turbulent shifts in demographics, wobbling changes in the desires of restless populations, and the alternation of local and regional political wings. Even at the scale of a single building, the initial program brief is typically shaken up and reorganized during the planning process. When a portion of program is taken away, the architect is often involved in inventing new programs to occupy the building envelope.

In case of programmatic fluctuation, this disquietude can be taken as an advantage. Is programmatic indeterminacy a disaster for any architect who aspires to a relationship of form to function? Will the profusion of the decorative skin approach—with its unrelated historicist pastiche—prevail simply as a solution for internal indeterminacy?

Let the architect project spaces and buildings with a conscious intention of programmatic richness. The palpitation of the internal functions in the large project unfurls against an open thought process of programmatic association. The open association of spatial sketches to program suggestions (action images) is fertilized by gathering and juxtaposing.

We would not call for a new disordered architecture to match the disorder of culture; such duplication achieves no other dimension, but simply expresses an affirmation of the chaotic. Rather, we would propose experiments in search of new orders, the projection of new relationships. This is not to transpose our study into a system or method, and yet the energy inherent in the opening up of relationships presents us with a continuity of ordering that compels reflection.

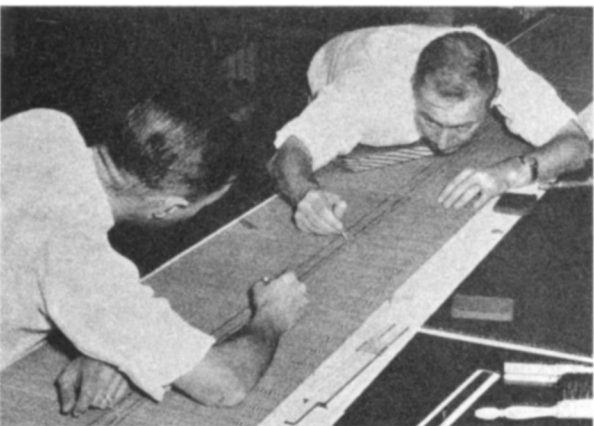
Consider the experience of reading a comprehensive morning newspaper. Here is indication of an ordering of life in society. Perhaps the following untenable juxtaposition should be paralleled in urban



*Chi-chi has a bath
against her will*



*Enclosure for desert
welding*



*Teleology; the study of
final causes*

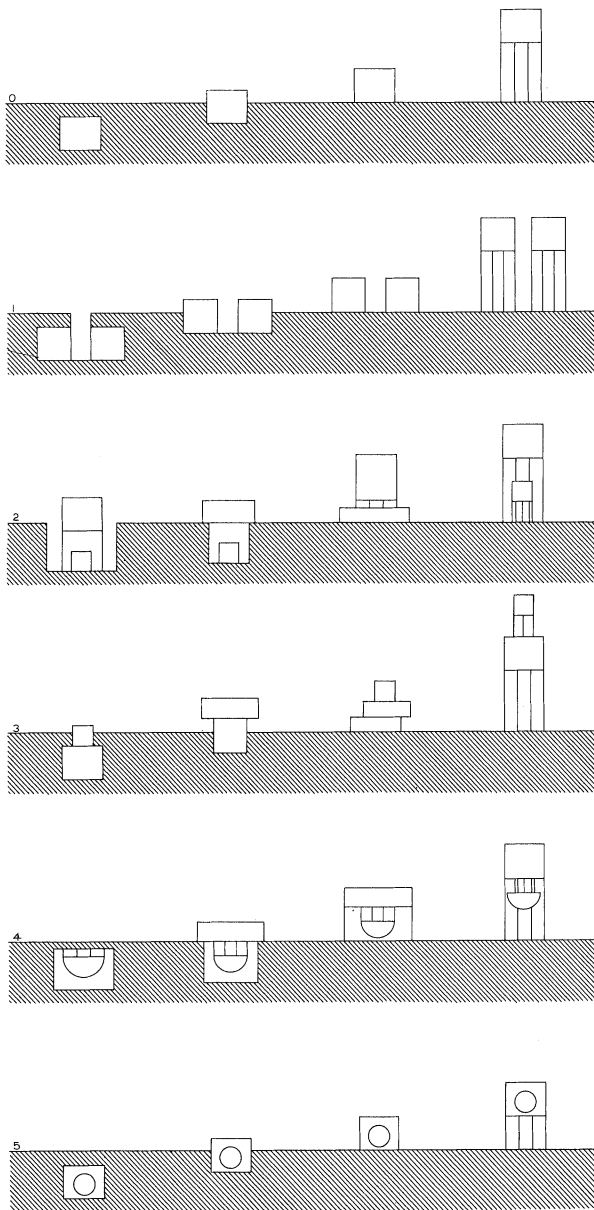
*Note: Thanks to the
Dialogical Principle
of Mikhail Bakhtin, two
opposites are held
together but not opposed.*

terms: beside an article describing a billion-ton floating island of ice with twelve research buildings that is drifting around the North Pole, is an article on the construction of a 24 foot diameter water tunnel, and a piece on the austerity program of a religious cult. Next to a column on insomnia and the sleep movement of plants is a huge diagram of the "Pacific Rim" trade network, an article on Japanese factories in Mexico, and a photograph of a hole in the ozone layer over the South Pole. To precisely translate thoughts and feelings sparked by incredulous relationships is as problematic as translating an English word into all of the world's 2796 languages. Precision of the rational gives way to intuition; subjective dimensions ground physical dimensions.

Semi-automatic programming questions, compares and contemplates diverse combinations without decisive claims to instrumentality. Its purpose is to set one to think.

A spatial arrangement, a smell and a musical phrase may be imagined simultaneously. Depending on the awareness and imagination of the perceiver, an initial visual field can provoke subject matter, and imply programs. We could speak of the sounds implied by an array of brittle linear forms, or the way a view smells. An individual's cultural associations, recognition of materials and imagination of their properties, and the physiological effects of space and enclosure all present individual limitations. The perceiver's angle of vision and preconception is potentially open to the adhesion of unforeseen associations. Rather than allowing prejudice to be a primary subjective determinant, one could induce program associations by heightening the possible number of programs to occupy an urban setting.

Isolated buildings of a single function, the norm of the suburban, are scarce in the compression of a city where abutment and connection of buildings cause functions to intersect. Various urban building relationships can be organized in an analytical chart suggesting corresponding programmatic relations.



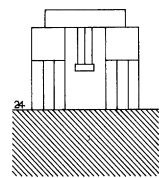
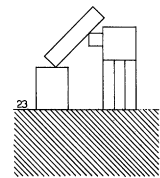
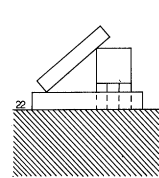
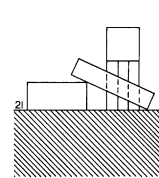
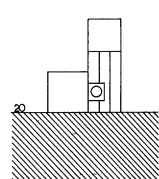
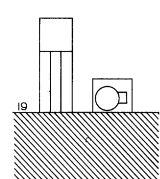
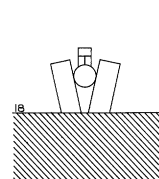
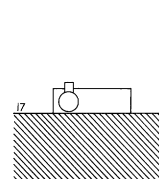
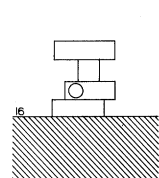
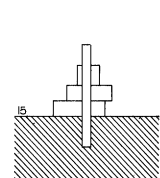
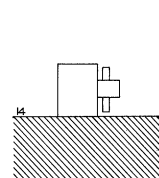
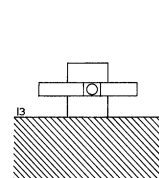
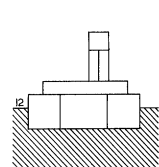
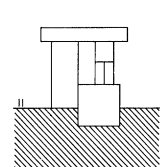
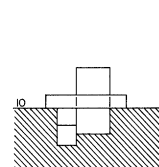
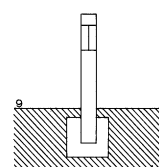
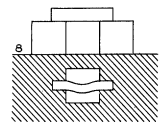
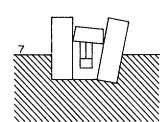
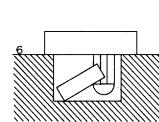
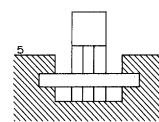
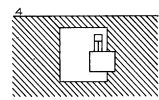
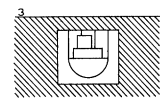
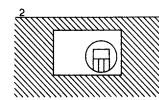
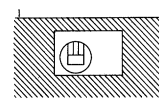
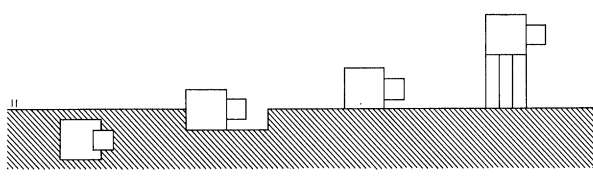
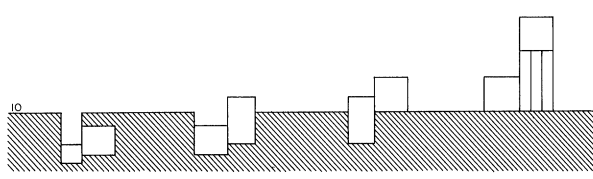
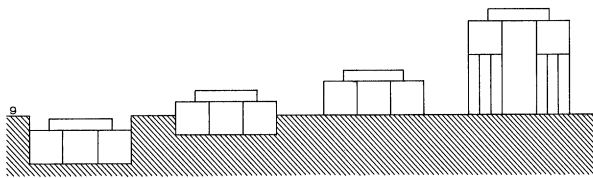
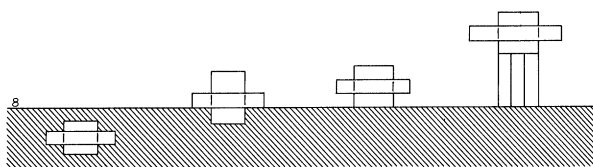
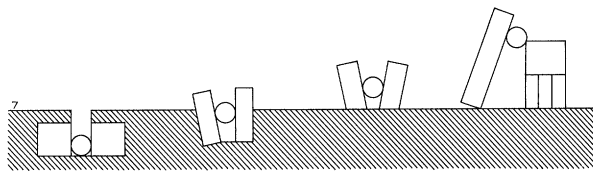
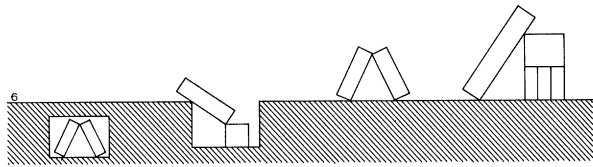
- 0 *Primary relations*
- 1 *Near*
- 2 *Over*
- 3 *Atop*
- 4 *Under*
- 5 *Within*

Correlational Charts

A table of “Links and Correlations” suggests classification: analyzing interrelationships of architectural form in the modern city. If the simple reconstitution of historic building types is frustrated by modern urban complexities, the interrelational properties of these complexities may be a way of rethinking urban form and program.

Correlations draw attention toward interdependent characteristics in an urban field. Diverse building sections and program relations are a kind of prepositional chart suggesting the intrinsic intersection of programs as a bond, fastening or disjunctive force. This analytical observation differs fundamentally from that of the typological study of the city. Here the minor link is the basis of a primary internal order (allowing for programmatic flux). Overlapping rather than separated, functions inhabit hybrid building forms. The relation between things is the focus, rather than the object-type. The zero point of such a relational chart is a section at the surface of the earth. We begin with the four primary relationships: under the earth, in the earth, on the earth, and over the earth. A second condition of relation extends the analysis to the second degree, and so on toward a correlative chart.

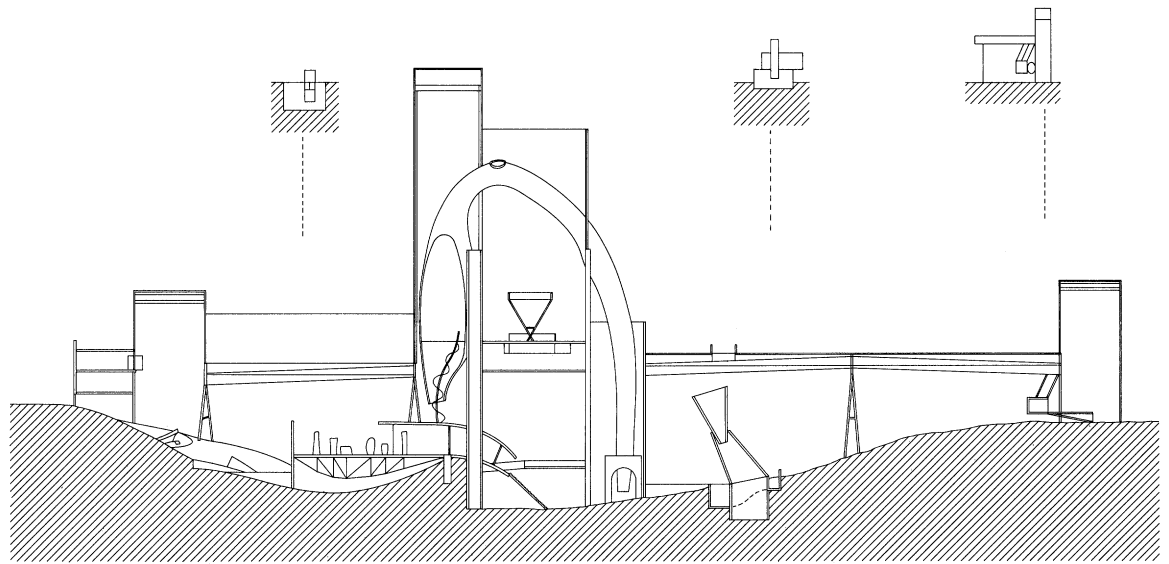
Despite the regularity of this arrangement, each individual cross-product has a different implication. Each diagram suggests a condition that, however, is too vague to be identified immediately. To be developed in another form, the condition is sounded for its sectional implications. What is open, closed, connected or detached directs the analysis and clarifies an implied program.



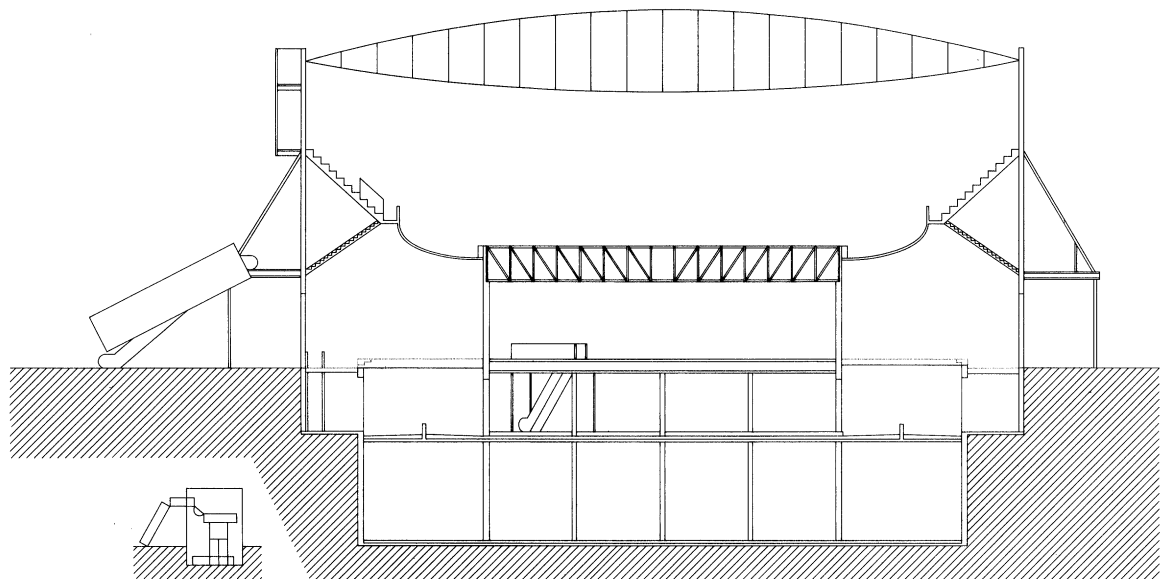
- 6 *Against*
- 7 *Between*
- 8 *Through*
- 9 *Across*
- 10 *Beside*
- 11 *From*

- 1 *Under within a within (below)*
- 2 *Over within a within (below)*
- 3 *Atop an under (below)*
- 4 *Atop a from (below)*
- 5 *Over a through (in)*
- 6 *Against an under (in)*
- 7 *Under a between (in)*
- 8 *Across (on) over a through (under)*
- 9 *Atop a vertical through (in)*
- 10 *Through a beside (in)*
- 11 *Across an atop beside (on)*
- 12 *Atop an across (in)*
- 13 *Within a through (on)*

- 14 *Through a from (on)*
- 15 *Through atop (on)*
- 16 *Within atop (on)*
- 17 *From a within through (on)*
- 18 *Atop a between (on)*
- 19 *Above near from a within (on)*
- 20 *Within a from beside (above)*
- 21 *Over an against (on)*
- 22 *Against an over (above)*
- 23 *Across against a from (above)*
- 24 *Under an across (above)*



*Section through
Botanical Garden
(see Milan case study)*



*Section through Bus
Garage and Velodrome
(see Milan case study)*

Matter/Tactility

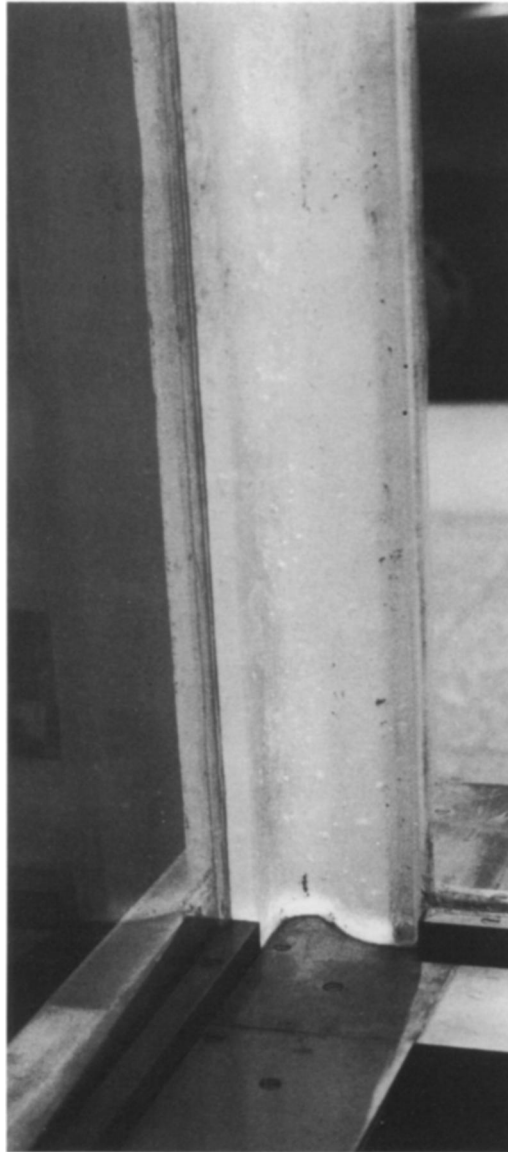
The space of a single room, like the vast space of a city, is defined by juxtapositions of matter. The stuff of which something is made has emotive qualities. The transparency of a membrane, the chalky dullness of a wall, the glossy reflection of opaque glass and a beam of sunlight intermesh in reciprocal relationships, forming the particular phenomena of a place. Given an architectural idea, the relationships of construction materials impose a dimension that penetrates perception through matter to tactility.

Matter interlocking with the perceiver's senses provides the detail that moves us beyond acute sight to tactility. From linearity, concavity and transparency to hardness, elasticity and dampness, the haptic realm opens.

But this is a time of simulacrum, in which most things exist in order to represent something else. Mind-numbing replicas proliferate. Profitable mis-direction of human creativity has turned what was mere replication into an internal transplantation of cultural dimensions. On a domestic scale, jerry-built houses with grotesque facades stand as miserable imitations of their more durable models.

For the imagist, simulation is the aim. What can be done with painted cardboard or facsimile plastic is expedient to the desired view. Wide-angle distortion of a color-corrected photograph becomes the final synthesis of an architectural project. The material and tactile dimensions of architecture are erased by the color photograph. Spatial proportions distended by lenses are now planned with the lens as an end. Uncritical and ambitious, the imagist-architect has allowed architecture to become simulation, oblivious to sensory essence.

If the imagist practices an architecture of "concealment," resistance takes form in an architecture of "revealing." Architecture of matter and tactility aims for



Cast glass corner

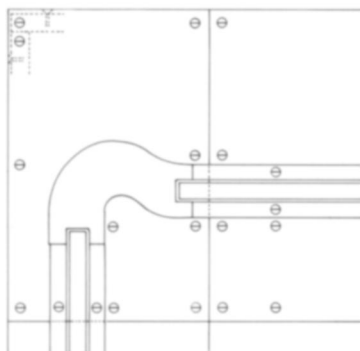
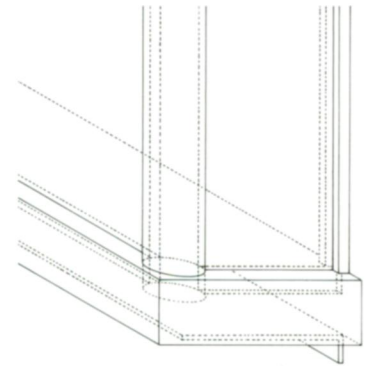


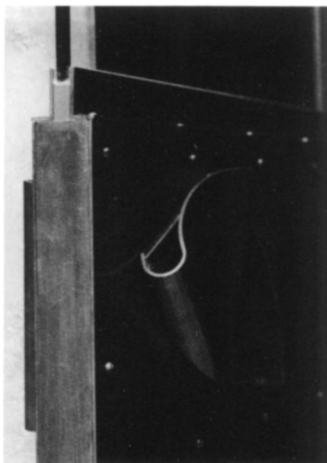
Diagram: cast glass corner



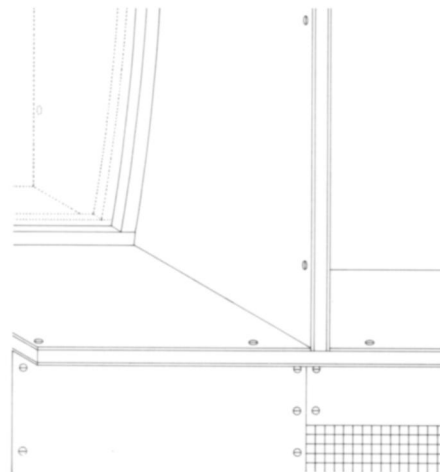
*Sunlight projecting
etched glass concept
diagram onto a wall*



*Diagram: three-way
glass corner*



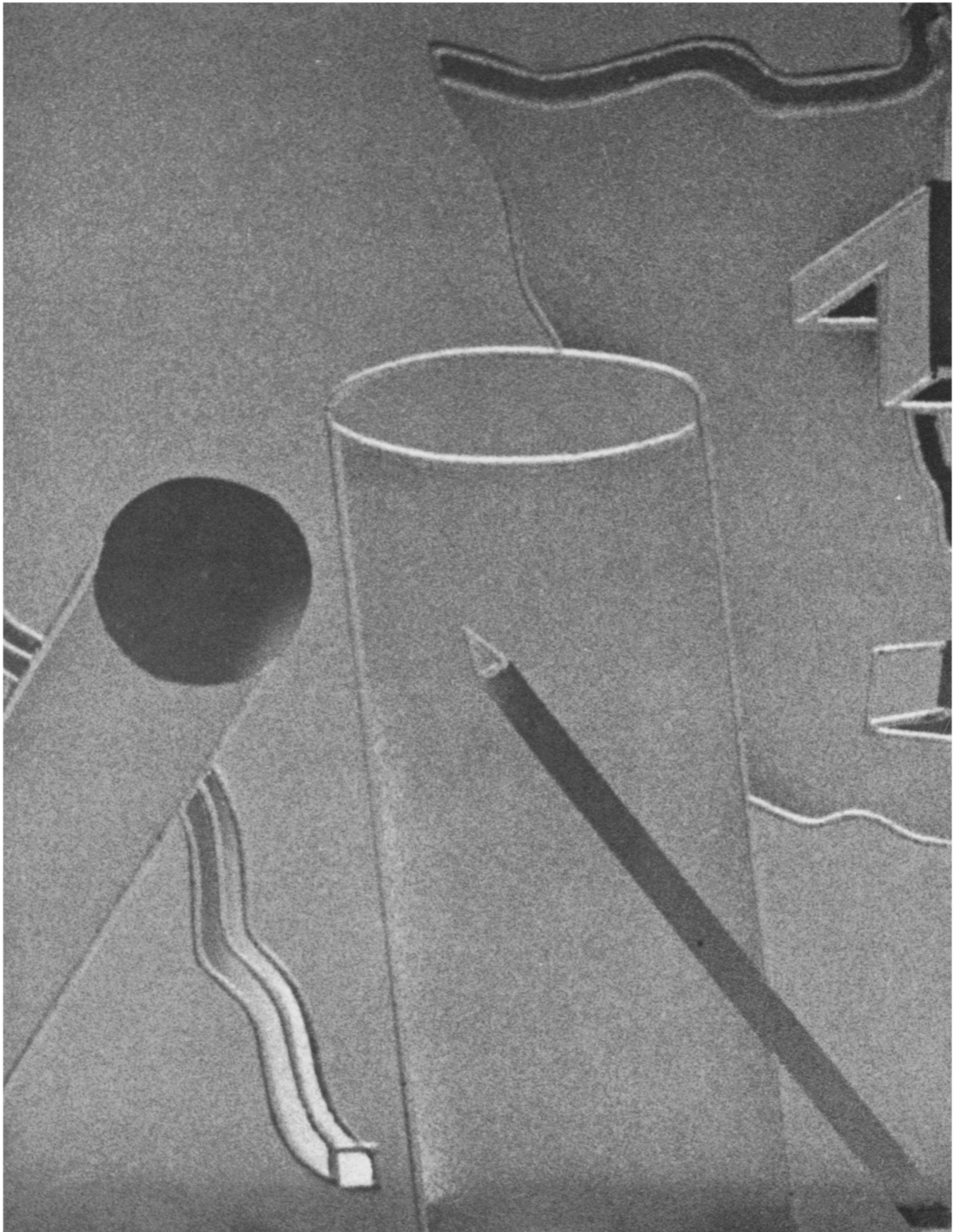
Bent metal push plate

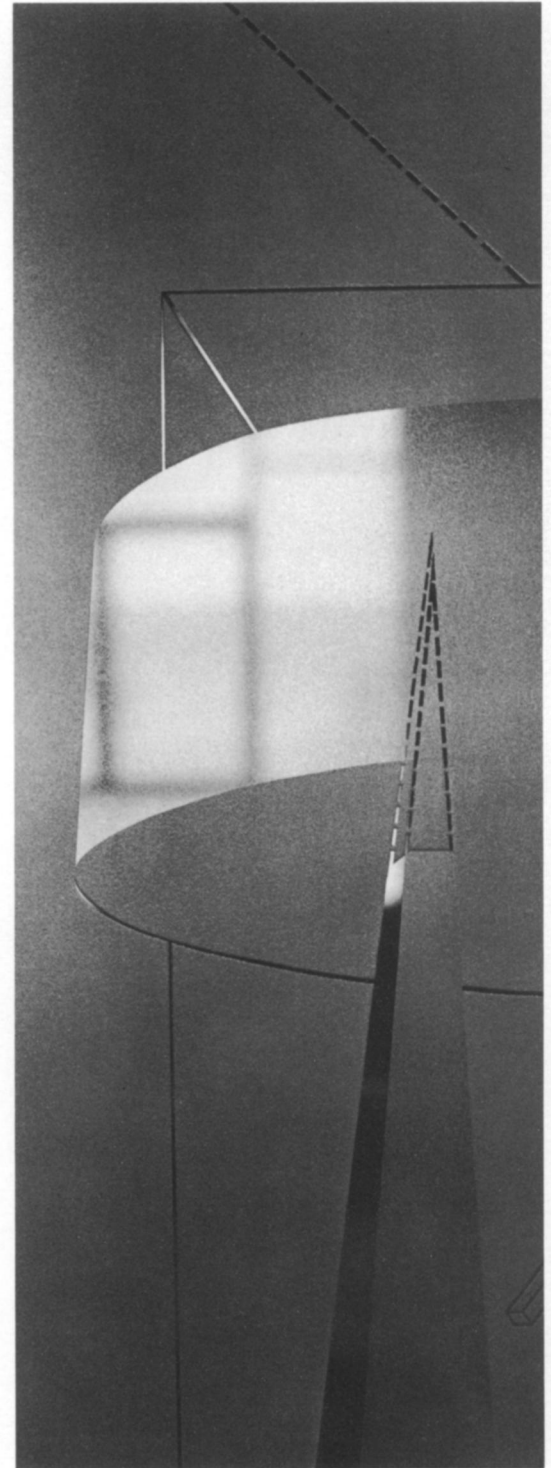


*Diagram: bent glass
between plates of acid
transformed brass*

a “poetics of revealing” (Martin Heidegger). “Revealing” requires an inspiration of joinery. A sense of the relation of detail to mass establishes a surface intensity and delicacy from the micro to the macro scale. Parallel to the emotive aspect of poetry, the emotive side of human nature is aroused by proportions and the tactile dimension. Initial concept provides the intellectual dimension that is given emotive form in material and detail. This relationship in a work establishes an emotional tie, in a psychological sense, to the experience of architecture. In a cultural sense, a decisive affirmation, even at the smallest scale, can bear out an argument for architecture over mere building (although this work is marginal in today’s society of simulation).

The link of perception through matter to the tactile is taken up in an effort to create qualities over quantities. Through an awareness of the necessity of craft in construction, we question the concept of our art. In ancient Greece, art was fused with the tasks of life. The word *techne* referred simultaneously to art, to a sense of philosophy, and to the skills of a craftsman.





*Concept studies drawn in
sandblasted glass:
concept + raw
material = ornament*

Case Study

Porta Vittoria, Milan



A project commissioned by the XVII Triennale of Milan for the exhibition *The Imagined Cities: An Italian Journey*, organized by Professor Pier Luigi Nicolini in Palazzo della Triennale, Milan, February–May 1987.

Site

A freight rail yard, now in disuse (part of the old railroad belt around Milan), bordered by blocks of housing of different types, the site fronts onto “Largo Marinai d’Italia,” a ragged park on land reclaimed from a poultry and vegetable market. It is in the nineteenth-century gridded portion of Milan, outside the historical center.

Program

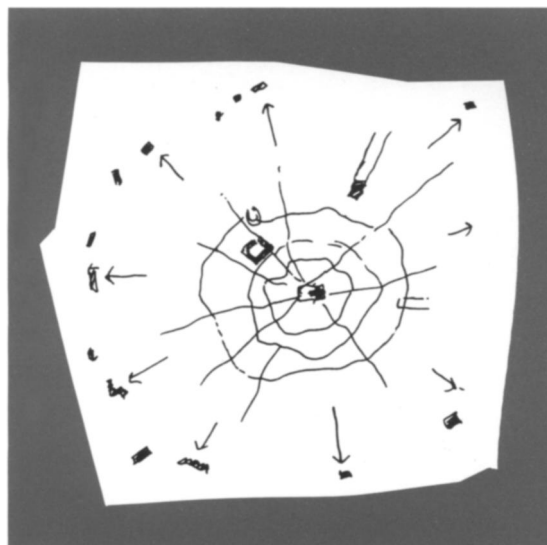
The only fixed program is the new “Passante” subway station, which is the catalyst provoking the rethinking of the area. Other functions to be located at the site include a bus station and garage for thirty buses; an air terminal station from the airport of Linate (which can use the Passante system for interconnection); hotels; offices; and some housing. The proposal is also meant to provoke consideration of other programs for the reclamation of this metropolitan site.

Urban Strategy

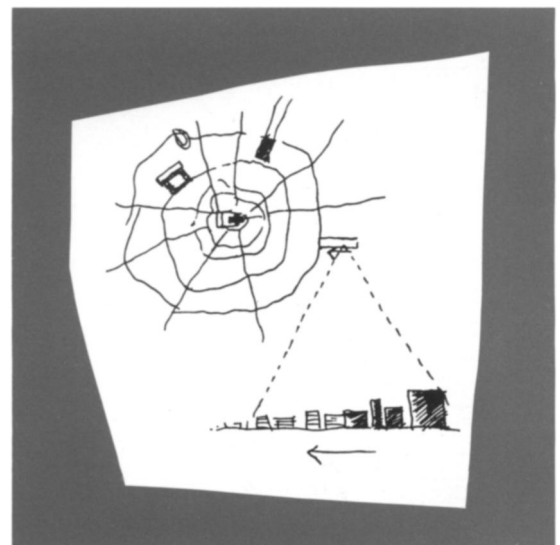
From a dense center, Milan unfolds in circles ringed by a patchwork grid that finally sprawls raggedly into the landscape. Against this centrifugal urban sprawl (from the dense core to the light periphery) a reversal is proposed: light and fine-grained toward the center— heavy and volumetric toward the periphery. This proposal projects a new outer ring of density and intensity, adjoining the rolling green of a reconstituted landscape.

*Milan’s canals,
past and present*

*Centrifugal: existing
dense core, dispersed
periphery; Milan
sprawls into landscape*



*Centripetal: proposed
dense outer ring
contains the city and
clarifies the landscape*



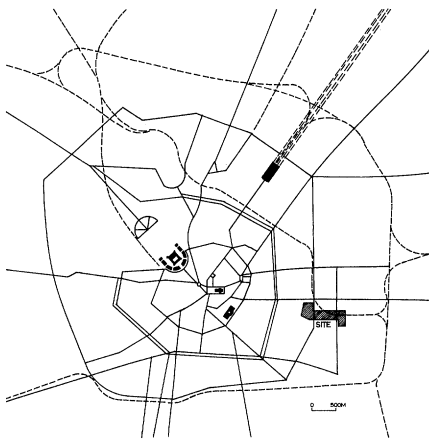
Site Elements

For the existing park, Largo Marinai d'Italia, a giant pond is proposed to reconcile the park with its name. The Palazzina Liberty is restored as the Dario Fo Pavilion and is accessible by rowboat only. A series of floating walkways connects a seaman's exhibition: residential apartments hover over tiny objects: an oar, a horn, a carving. Old sailors discuss the artifacts with passing visitors; stories are the material of the floating exhibition.

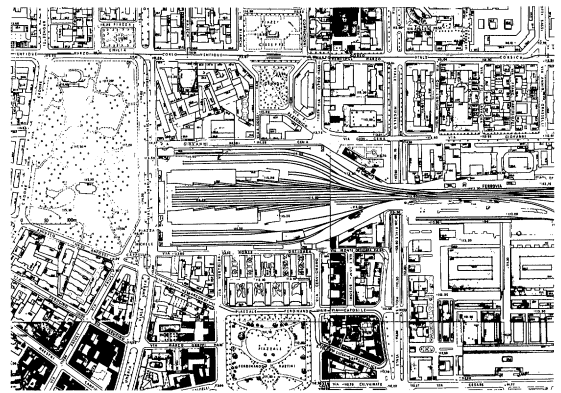
At the edge of the pond is a large metronomelike Monument to Toil, in memory of the loading and unloading of goods that once filled this site. As the slow movement of each pipe beam reaches the end of a beat, a drop of water is emitted from its top. Nearby, an aviary housing two white doves juts out of the park, bringing light to an underground assemblage.

Across Viale Umbria, in a Garden of Sounds, the park infiltrates the urban area. Within the garden is a seasonal children's zoo whose animals require a variety of cages and enclosures (the goat, the chicken, the cow, etc.). Other little programs are implied by the titles of various areas: The See-Saw, Fishing, The Picnic, The Water-chute, The Sleigh, La Commedia Italiana, The Octopus, Hunting, Fireworks, Bocci Ball.

To the south of the site is a large public Botanical Garden with glass-roofed forms in a sprouting diversity parallel to the vegetation within. Over the sloping earthen floor of the interior are areas for experimental botany, checker and chess tables and meeting tables. These are scattered throughout the green density of the vegetation. On the ground of the eastern portion is a darkened hall containing a cinema that dissects its interior. The public is exposed to back-projection on constructed objects, multiple separation and other cinematic experiments.

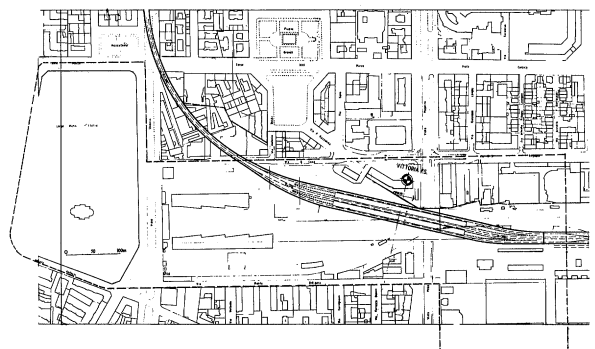


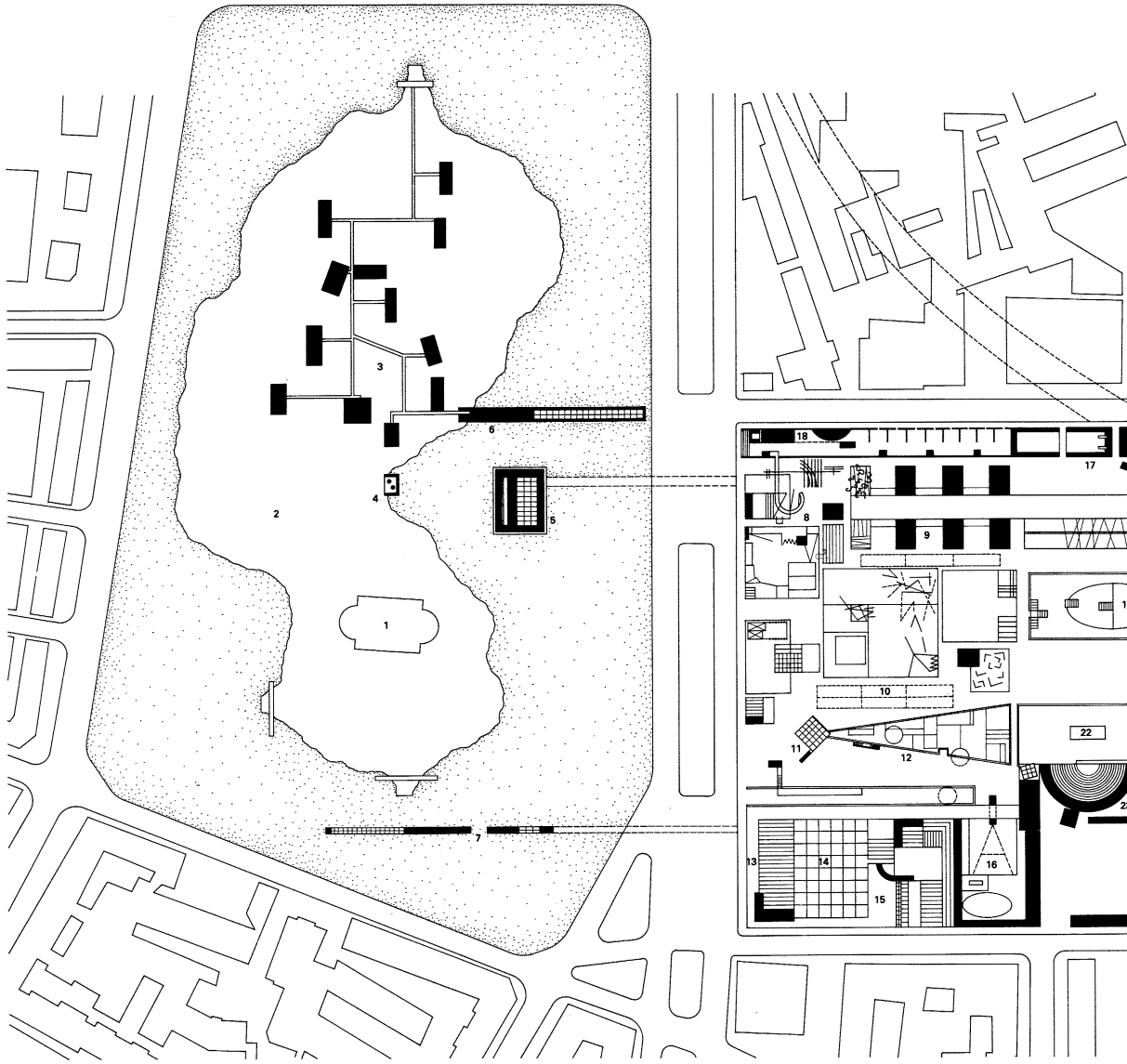
City of Milan



Existing Porta Vittoria site

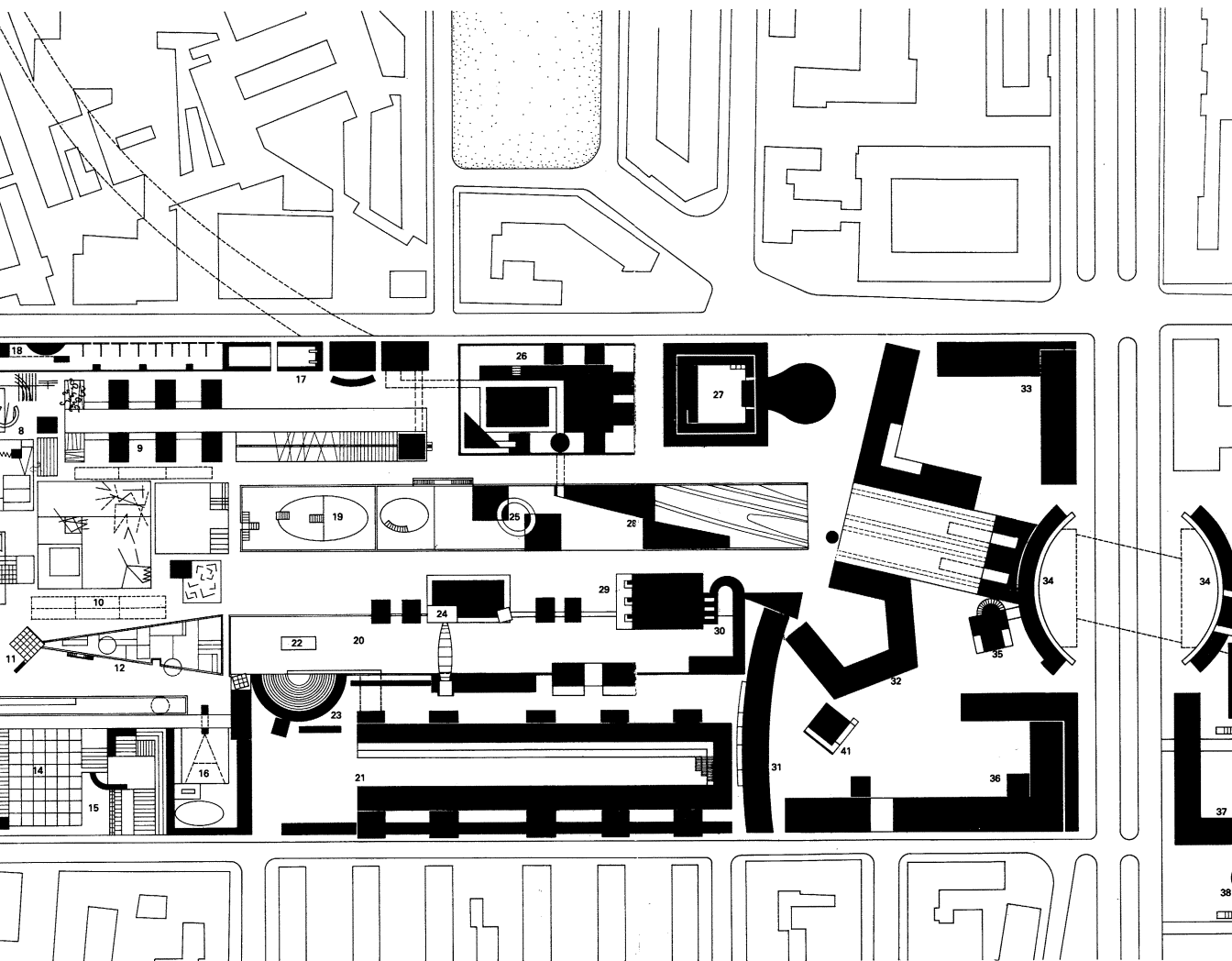
Site with Subway Station by Comune di Milano





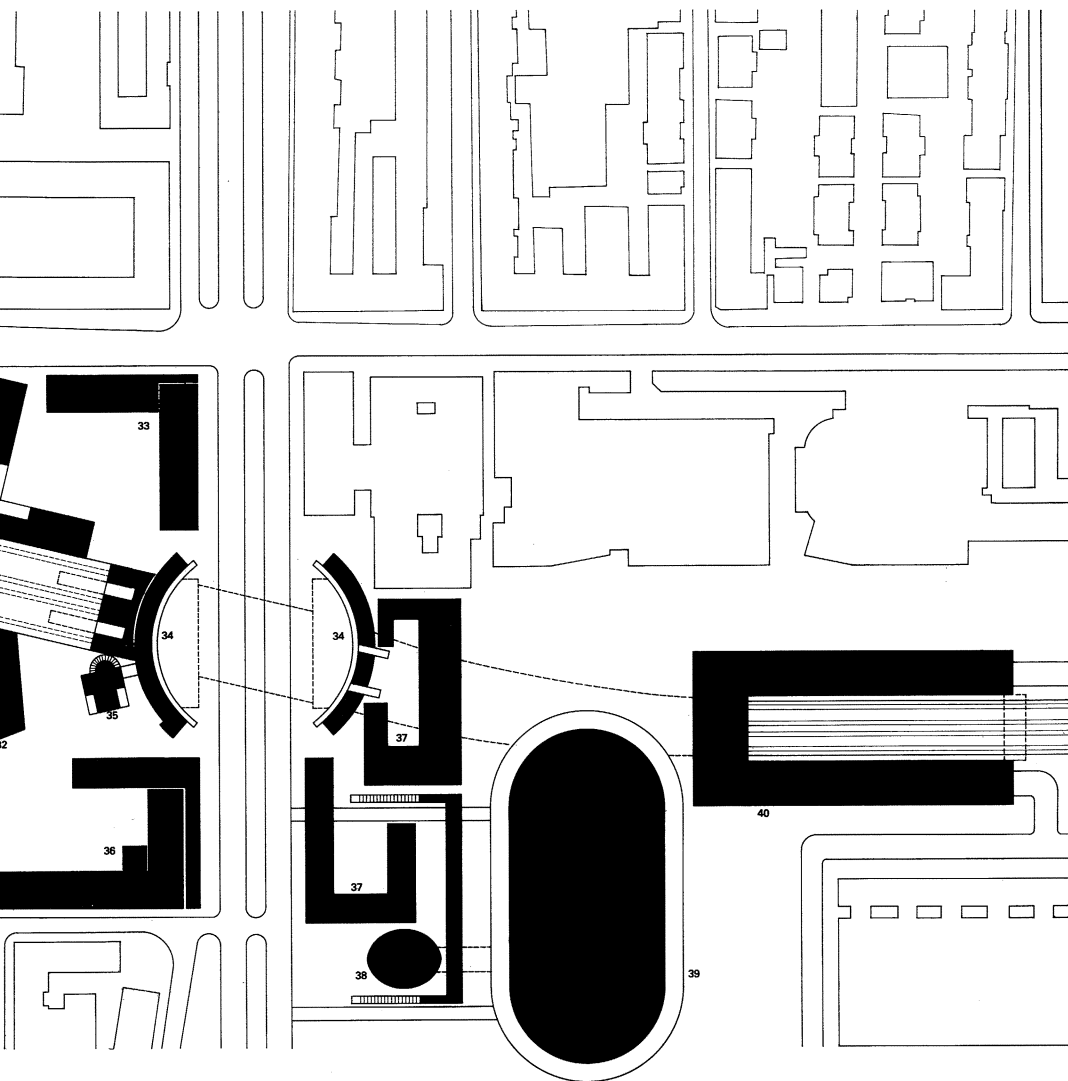
Project site plan:

- | | | | |
|---|---------------------------------------|---|--|
| 1 <i>Dario Fo Pavilion
(existing Palazzina
Liberty)</i> | 9 <i>Transients' Canal
Houses</i> | 18 <i>Café/Communal
Treadmill</i> | 27 <i>Museum with
Cinematic Insertions</i> |
| 2 <i>New Pond</i> | 10 <i>Bocci Ball Courts</i> | 19 <i>Elliptical Passage</i> | 28 <i>Shear Workshops</i> |
| 3 <i>Seamen's
Rooms/Floating
Walkways</i> | 11 <i>Primal Soup Kitchen</i> | 20 <i>Elongated Water
Basin</i> | 29 <i>Delegate Interview
Switchback</i> |
| 4 <i>Monument to Toil</i> | 12 <i>Evolutionary Zoo</i> | 21 <i>Tiered Housing Block
with Corresponding
Tower</i> | 30 <i>Three-Lobbed
Neck/Archival Library</i> |
| 5 <i>Aviary/Health Club</i> | 13 <i>Botanical Garden</i> | 22 <i>Jack-Up Rig/Stage</i> | 31 <i>Bureaucratic
Double-Flux Slab</i> |
| 6 <i>Seamen's Hotel
Lobby/Exhibition</i> | 14 <i>Playground/
Game Tables</i> | 23 <i>Amphitheater</i> | 32 <i>Four-Sided Pentagon</i> |
| 7 <i>Transfer Chambers/
Public subject</i> | 15 <i>Experimental Botany</i> | 24 <i>Lovers' Hotel/
Architectural Bridge</i> | 33 <i>Interlocking
Office/Housing</i> |
| | 16 <i>Dissecting Cinema</i> | | |
| | 17 <i>Spectator and
Audience</i> | | |

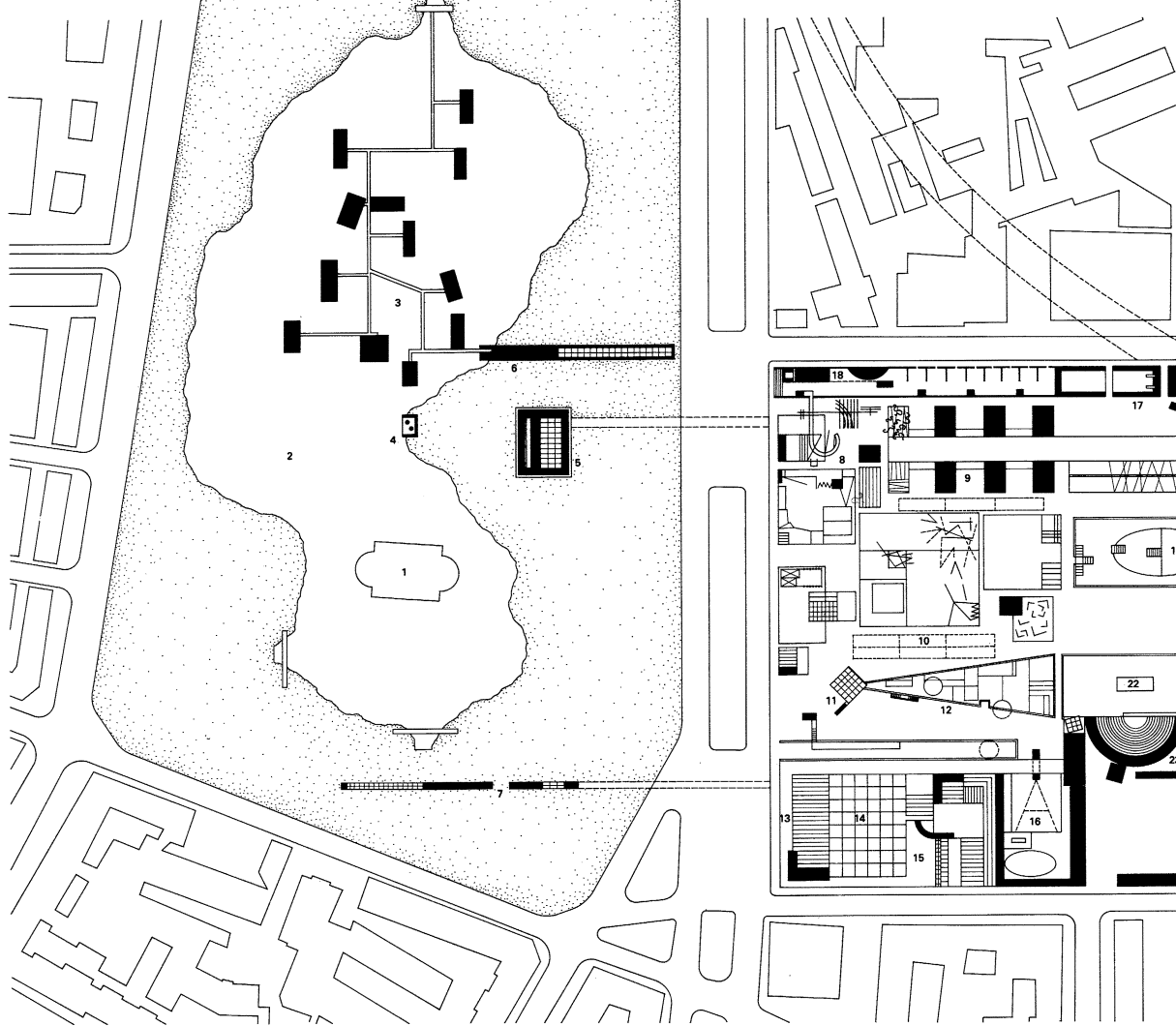


- 27 *Museum with Cinematic Insertions*
- 28 *Shear Workshops*
- 29 *Delegate Interview Switchback*
- 30 *Three-Lobbed Neck/Archival Library*
- 31 *Bureaucratic Double-Flux Slab*
- 32 *Four-Sided Pentagon*
- 33 *Interlocking Office/Housing*
- 34 *Passante Train Station/Shops*
- 35 *Control Tower/Administration*
- 36 *Corner Hotel/Offices*
- 37 *Office Block*
- 38 *Air Terminal/Ticketing*
- 39 *Bus Garage/Velodrome*
- 40 *Parking Garage/Arrival*

Bounding the Block
 steps and passages into
 for aquatic activities and
 for unhappy lovers. The
 set back-to-back. On the
 café-lounge and a wine
 portion of the site a
 Nearby, a public gym
 west is a school of the
 room towers; visiting
 connects to two wedges

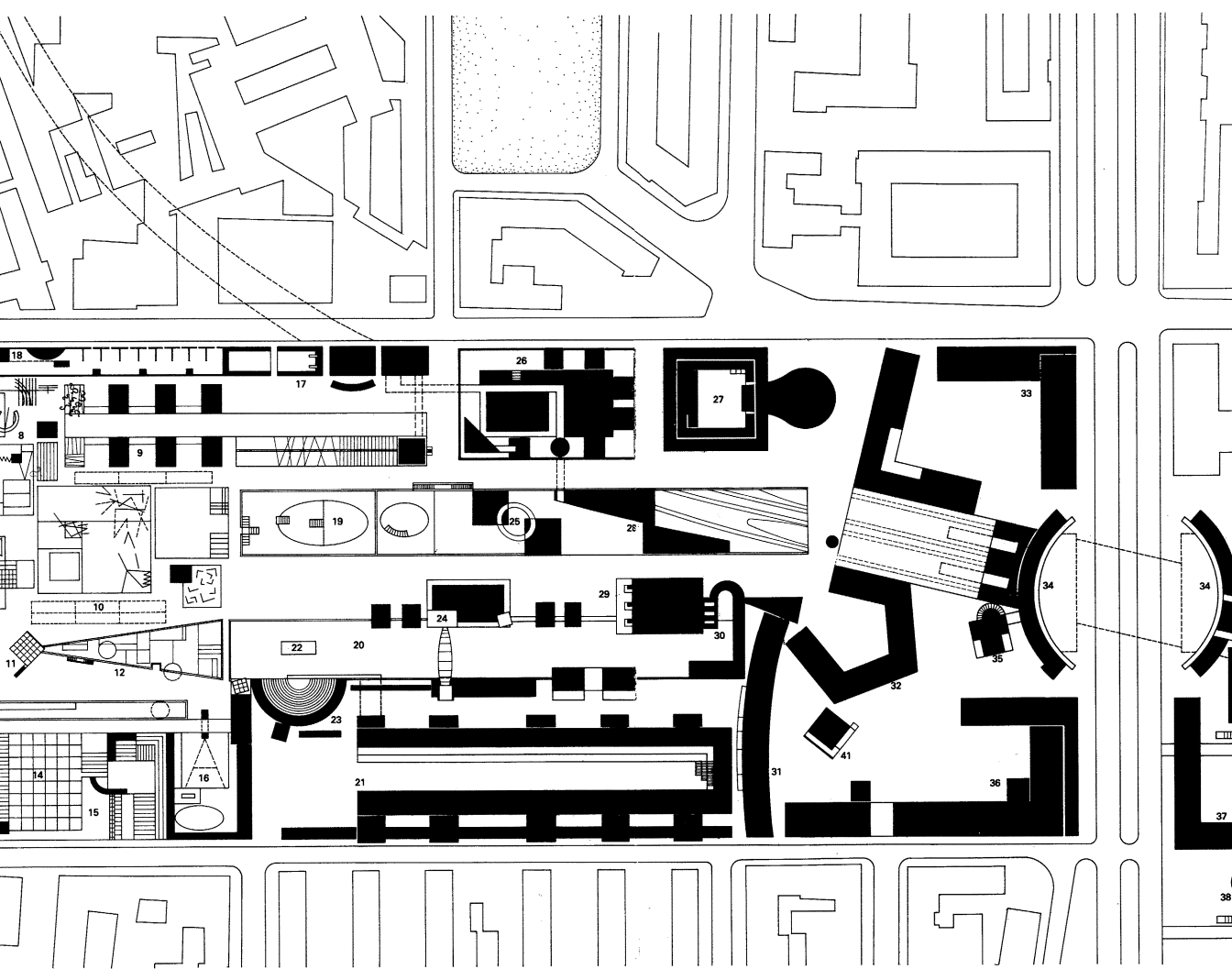


Bounding the Botanical Garden is a large public fountain that is negotiated via stone steps and passages interwoven with cascades of water. The fountain opens onto a long basin for aquatic activities and barge-borne theatrical events. At the edge of this opening is a hotel for unhappy lovers. The plan has no interior corridors, rather all the rooms of the hotel are set back-to-back. One large glass corridor belts the building. At the top is a crooked café-lounge and a wiry truss containing a footbridge to a suspended chapel. On the northeast portion of the site a water channel is flanked by rudimentary housing for the homeless. Nearby, a public gymnasium is organized in a strip interwoven with spectator areas. To the west is a school of the humanities. Its central block of lecture rooms is banded by study room towers; visiting professors live in the upper portions. From the main building, a walkway connects to two wedge-shaped interrelated workshop studios. To the west a ramp cycles



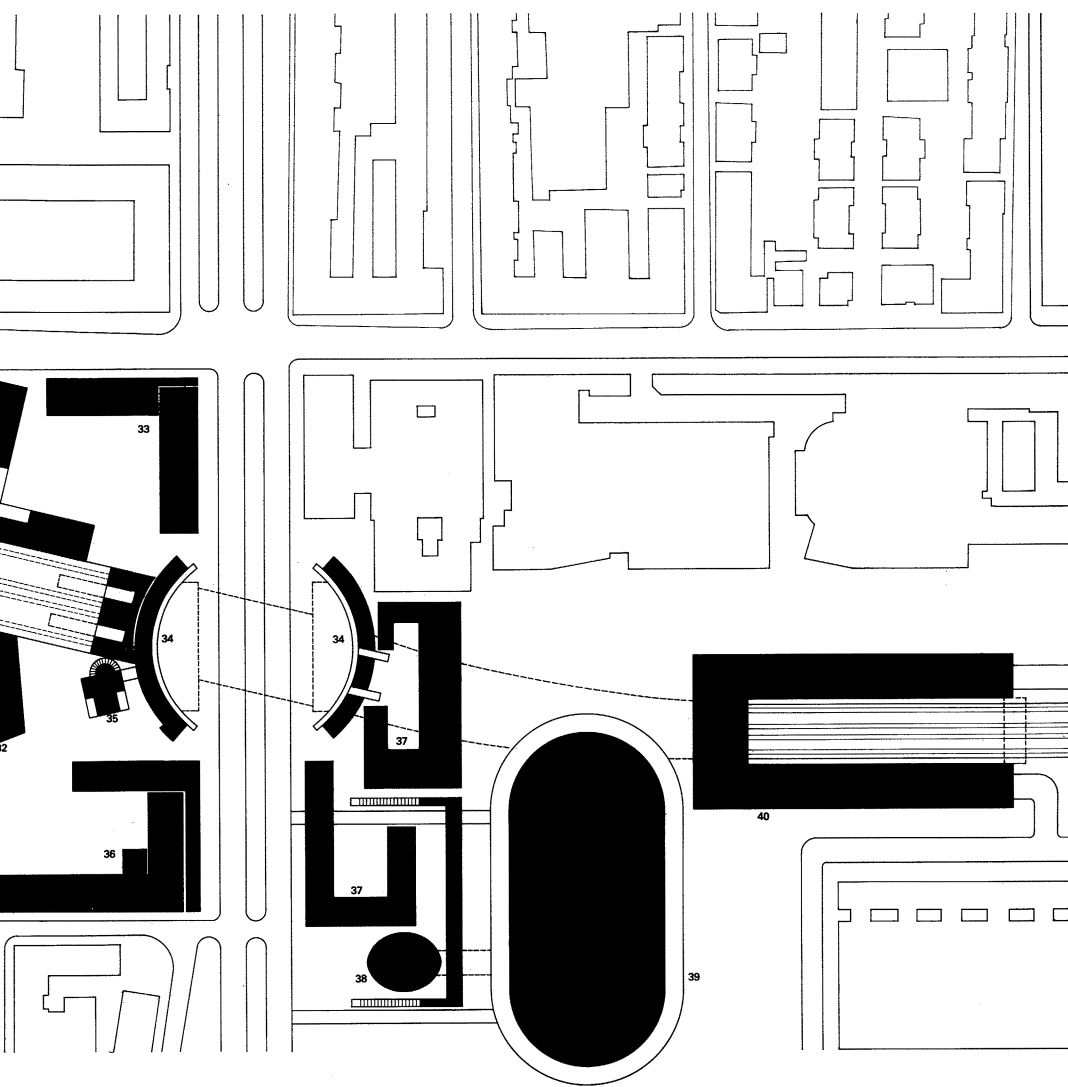
Project site plan:

- | | | | |
|---|--|---|--|
| 1 <i>Dario Fo Pavilion</i>
<i>(existing Palazzina</i>
<i>Liberty)</i> | 9 <i>Transients' Canal</i>
<i>Houses</i> | 18 <i>Café/Communal</i>
<i>Treadmill</i> | 27 <i>Museum with</i>
<i>Cinematic Insertions</i> |
| 2 <i>New Pond</i> | 10 <i>Bocci Ball Courts</i> | 19 <i>Elliptical Passage</i> | 28 <i>Shear Workshops</i> |
| 3 <i>Seamen's</i>
<i>Rooms/Floating</i>
<i>Walkways</i> | 11 <i>Primal Soup Kitchen</i> | 20 <i>Elongated Water</i>
<i>Basin</i> | 29 <i>Delegate Interview</i>
<i>Switchback</i> |
| 4 <i>Monument to Toil</i> | 12 <i>Evolutionary Zoo</i> | 21 <i>Tiered Housing Block</i>
<i>with Corresponding</i>
<i>Tower</i> | 30 <i>Three-Lobbed</i>
<i>Neck/Archival Library</i> |
| 5 <i>Aviary/Health Club</i> | 13 <i>Botanical Garden</i> | 22 <i>Jack-Up Rig/Stage</i> | 31 <i>Bureaucratic</i>
<i>Double-Flux Slab</i> |
| 6 <i>Seamen's Hotel</i>
<i>Lobby/Exhibition</i> | 14 <i>Playground/</i>
<i>Game Tables</i> | 23 <i>Amphitheater</i> | 32 <i>Four-Sided Pentagon</i> |
| 7 <i>Transfer Chambers/</i>
<i>Mushroom Garden</i> | 15 <i>Experimental Botany</i> | 24 <i>Lovers' Hotel/</i>
<i>Psychological Bridge</i> | 33 <i>Interlocking</i>
<i>Office/Housing</i> |
| 8 <i>Garden of Sounds</i> | 16 <i>Dissecting Cinema</i> | 25 <i>Correlating Facility</i> | |
| | 17 <i>Spectator and</i>
<i>Participant</i>
<i>Gymnasiums</i> | 26 <i>School of Humanities</i> | |

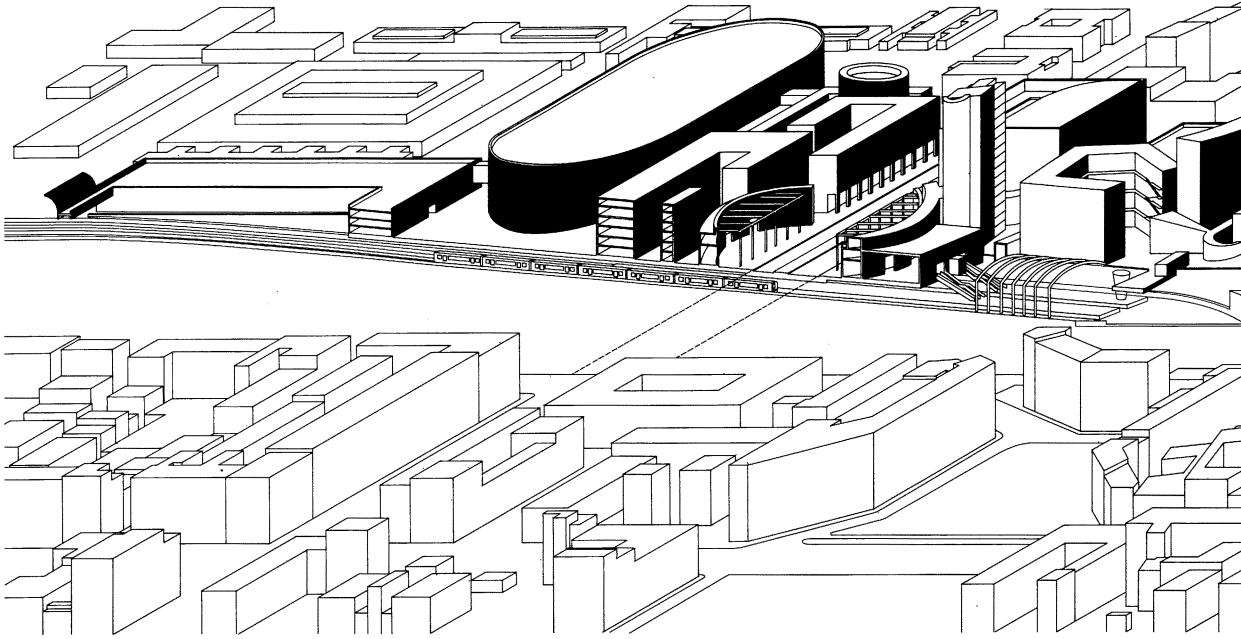


- | | |
|---|---|
| 27 <i>Museum with
Cinematic Insertions</i> | 34 <i>Passante Train
Station/Shops</i> |
| 28 <i>Shear Workshops</i> | 35 <i>Control Tower/
Administration</i> |
| 29 <i>Delegate Interview
Switchback</i> | 36 <i>Corner Hotel/Offices</i> |
| 30 <i>Three-Lobbied
Neck/Archival Library</i> | 37 <i>Office Block</i> |
| 31 <i>Bureaucratic
Double-Flux Slab</i> | 38 <i>Air Terminal/
Ticketing</i> |
| 32 <i>Four-Sided Pentagon</i> | 39 <i>Bus Garage/
Velodrome</i> |
| 33 <i>Interlocking
Office/Housing</i> | 40 <i>Parking Garage/
Switching Booth</i> |
| | 41 <i>House of Appeals and
Petitions</i> |

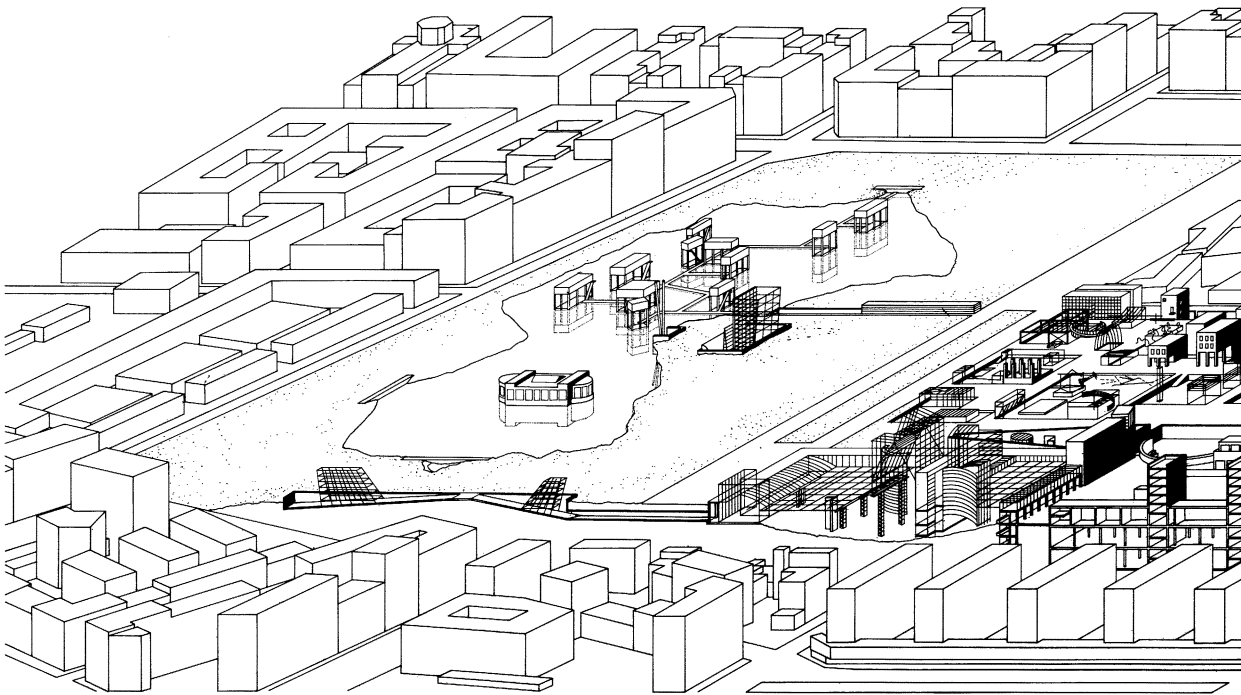
Bounding the B
 steps and passages int
 for aquatic activities a
 for unhappy lovers. T
 set back-to-back. On
 café-lounge and a win
 portion of the site a
 Nearby, a public gym
 west is a school of th
 room towers; visiting
 connects to two wedg
 through a two-part co
 arriving at a mechan



Bounding the Botanical Garden is a large public fountain that is negotiated via stone steps and passages interwoven with cascades of water. The fountain opens onto a long basin for aquatic activities and barge-borne theatrical events. At the edge of this opening is a hotel for unhappy lovers. The plan has no interior corridors, rather all the rooms of the hotel are set back-to-back. One large glass corridor belts the building. At the top is a crooked café-lounge and a wiry truss containing a footbridge to a suspended chapel. On the northeast portion of the site a water channel is flanked by rudimentary housing for the homeless. Nearby, a public gymnasium is organized in a strip interwoven with spectator areas. To the west is a school of the humanities. Its central block of lecture rooms is banded by study room towers; visiting professors live in the upper portions. From the main building, a walkway connects to two wedge-shaped interrelated workshop-studios. To the west a ramp cycles through a two-part correlating facility, leading upward into spaces more and more remote, arriving at a mechanical rooftop simulating teleological suspension.



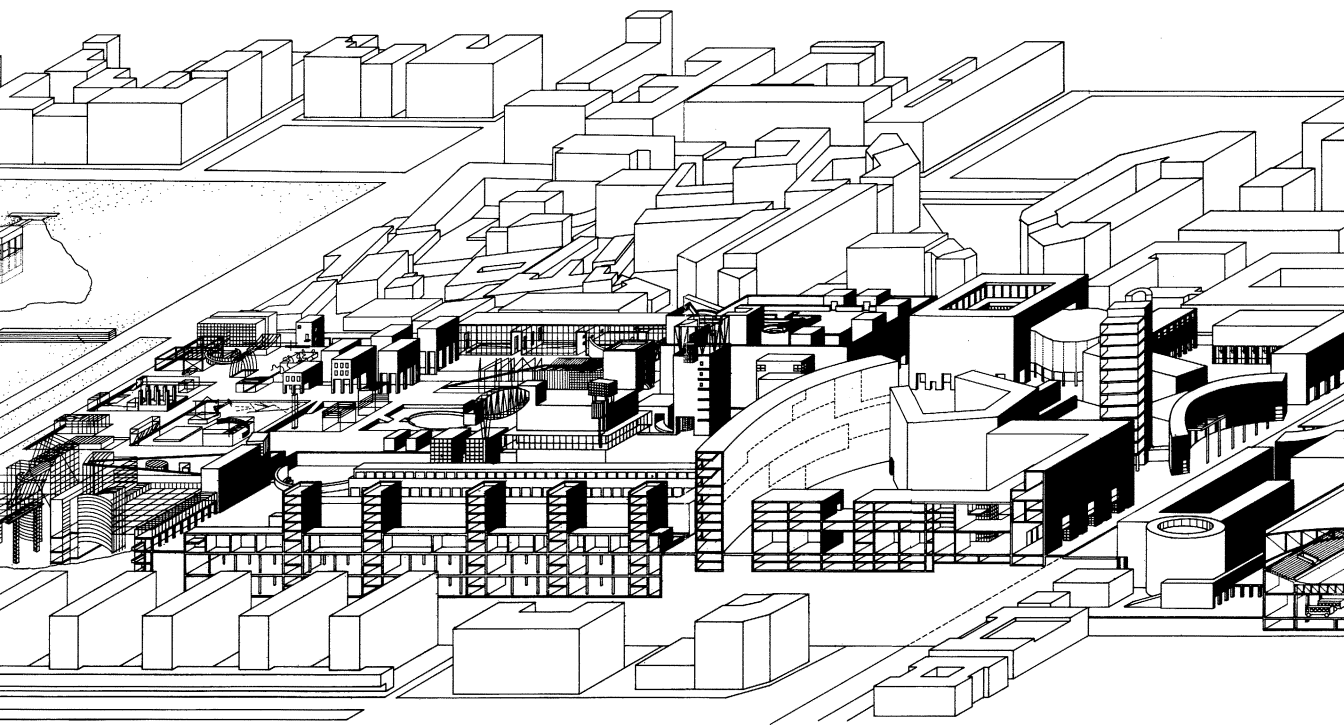
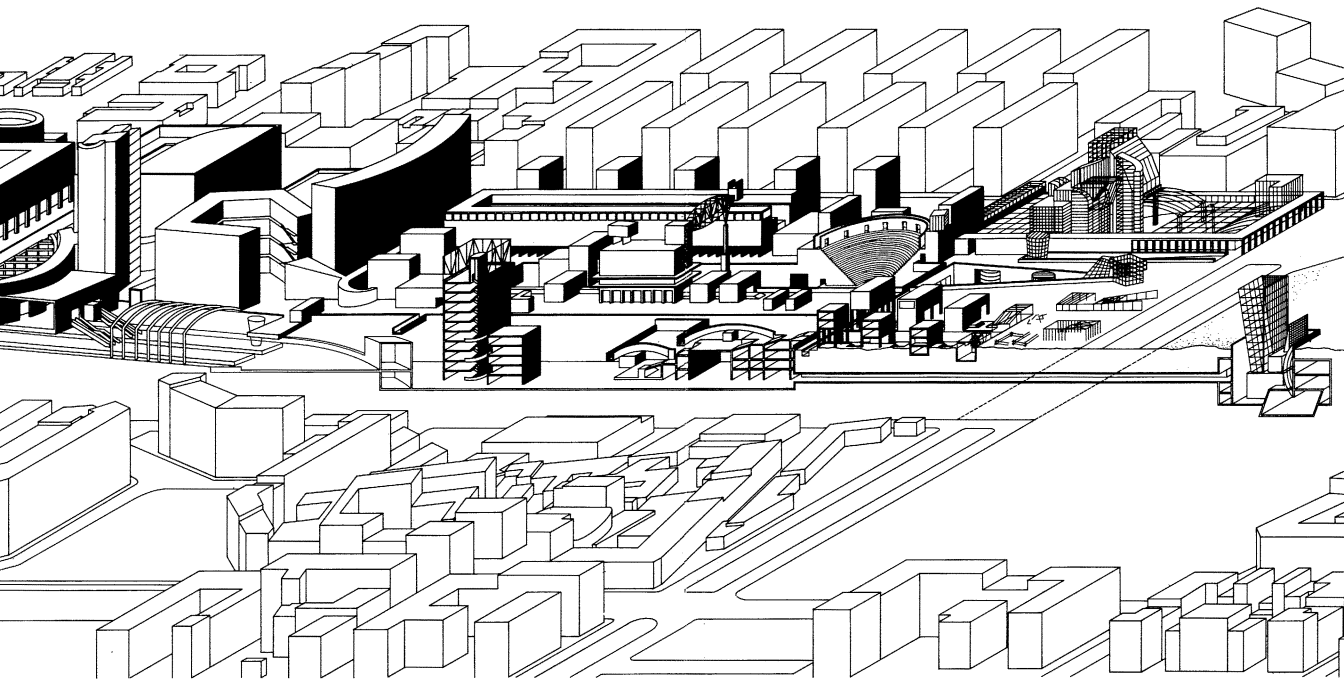
West-East Site Section



East-West Site Section

Near Via F. Rezzonico is a sanctuary of the muses filled with ancient stone. A modern cinema is inserted from the east. The public can move back and forth simulation to stone materiality.

The new subway station opens to the west onto an elongated gap. Here the through several activities, rising through an elliptical passage to the Garden Bureaucratic and administrative activities (formless and always in flux) are



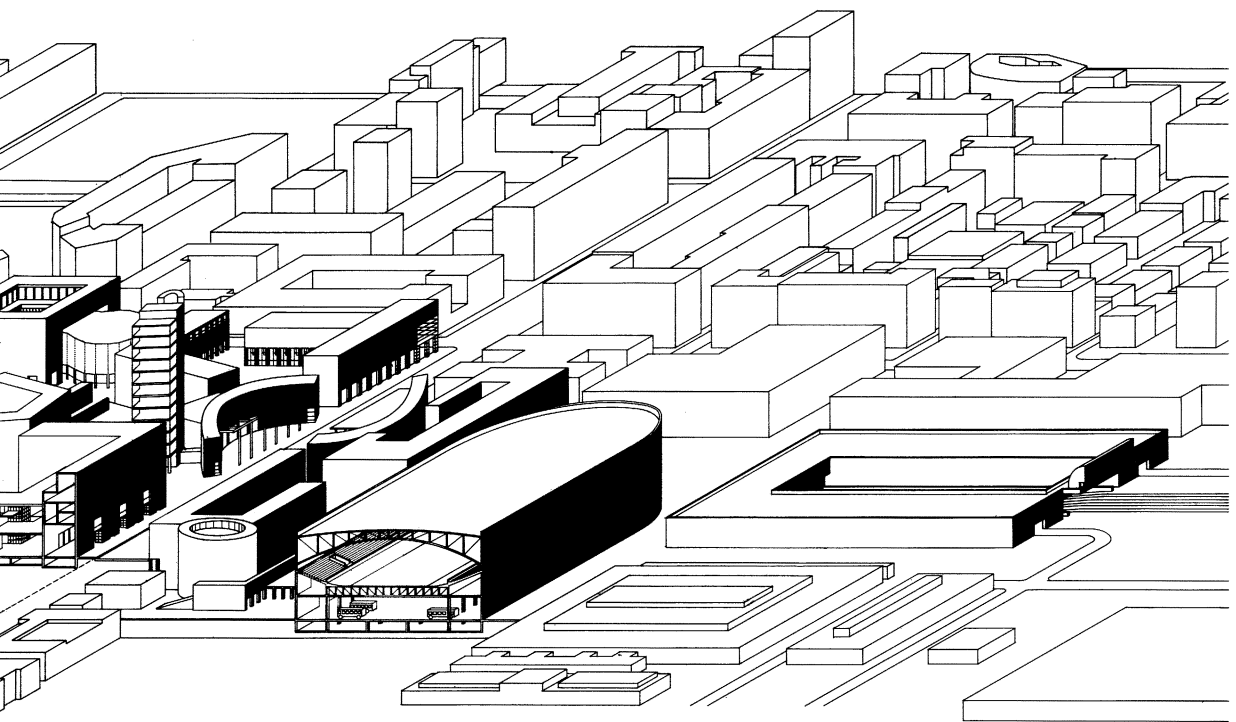
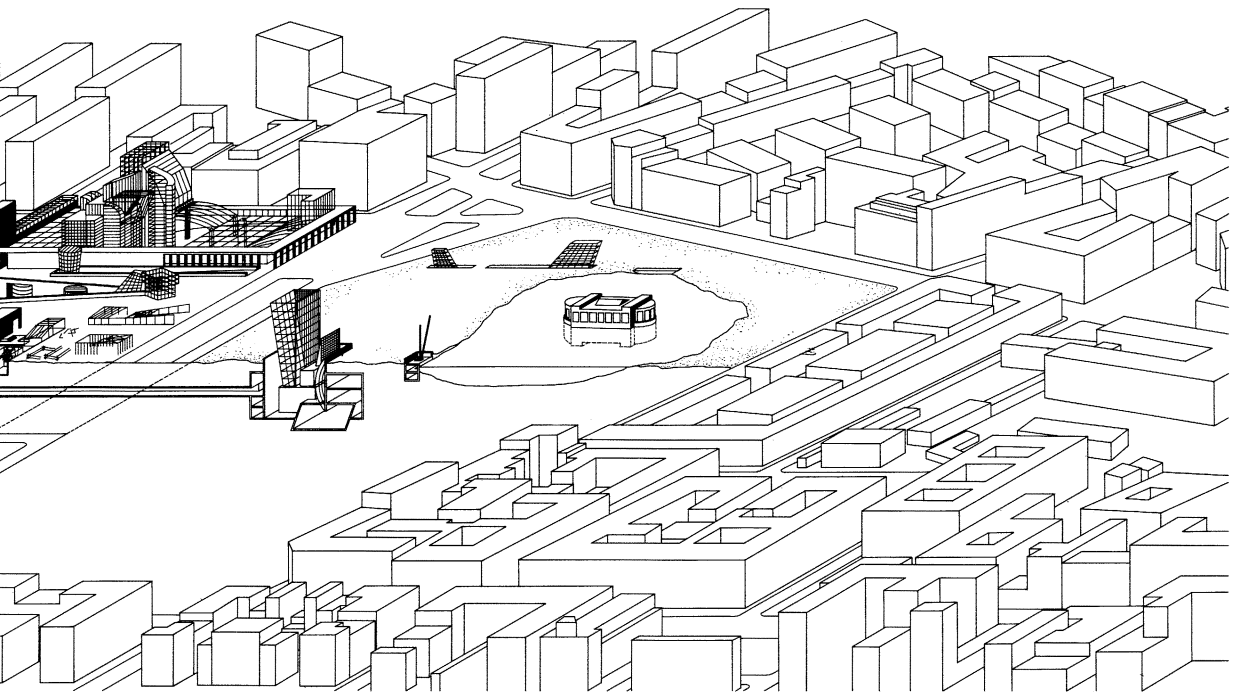
muses filled with ancient stone fragments.
 public can move back and forth from celluloid

onto an elongated gap. Here the visitor passes
 elliptical passage to the Garden of Sounds.

(harmless and always in flux) are given specific

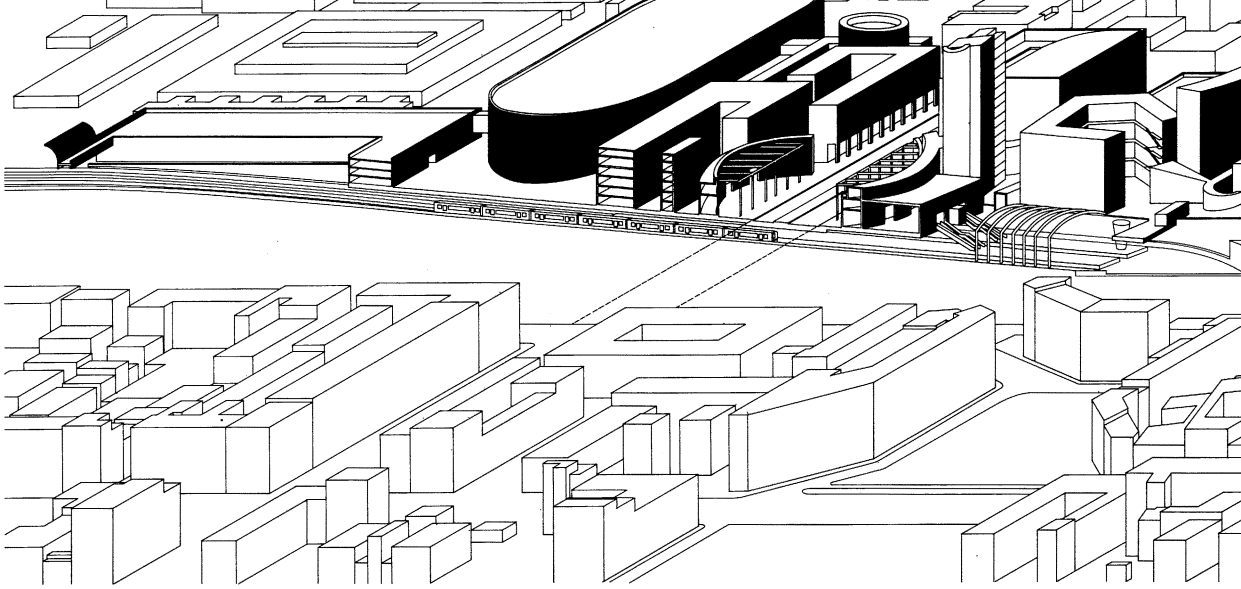
Across Viale Mugello
 airport connection station
 and velodrome.

Of these specific intentions
 intention depends on no
 of this city for which the

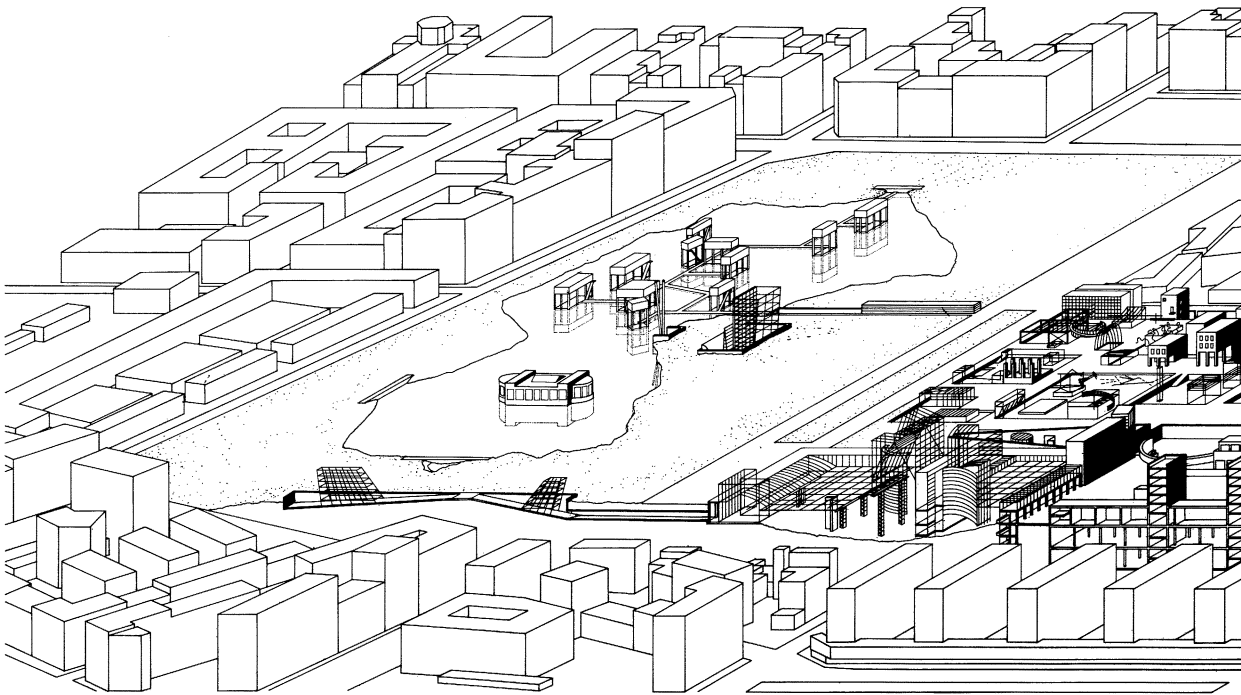


Across Viale Muguello, to the east, larger programs fit into the existing city fabric. The airport connection station sits there; adjacent is the bus garage, housed below a public arena and velodrome.

Of these specific ideas, several might be realized, and yet the overall strategy and intention depends on none of them. They serve only as examples for the figure in the landscape of this city for which the unknown is a source of optimism. To affirm the joy of the present,



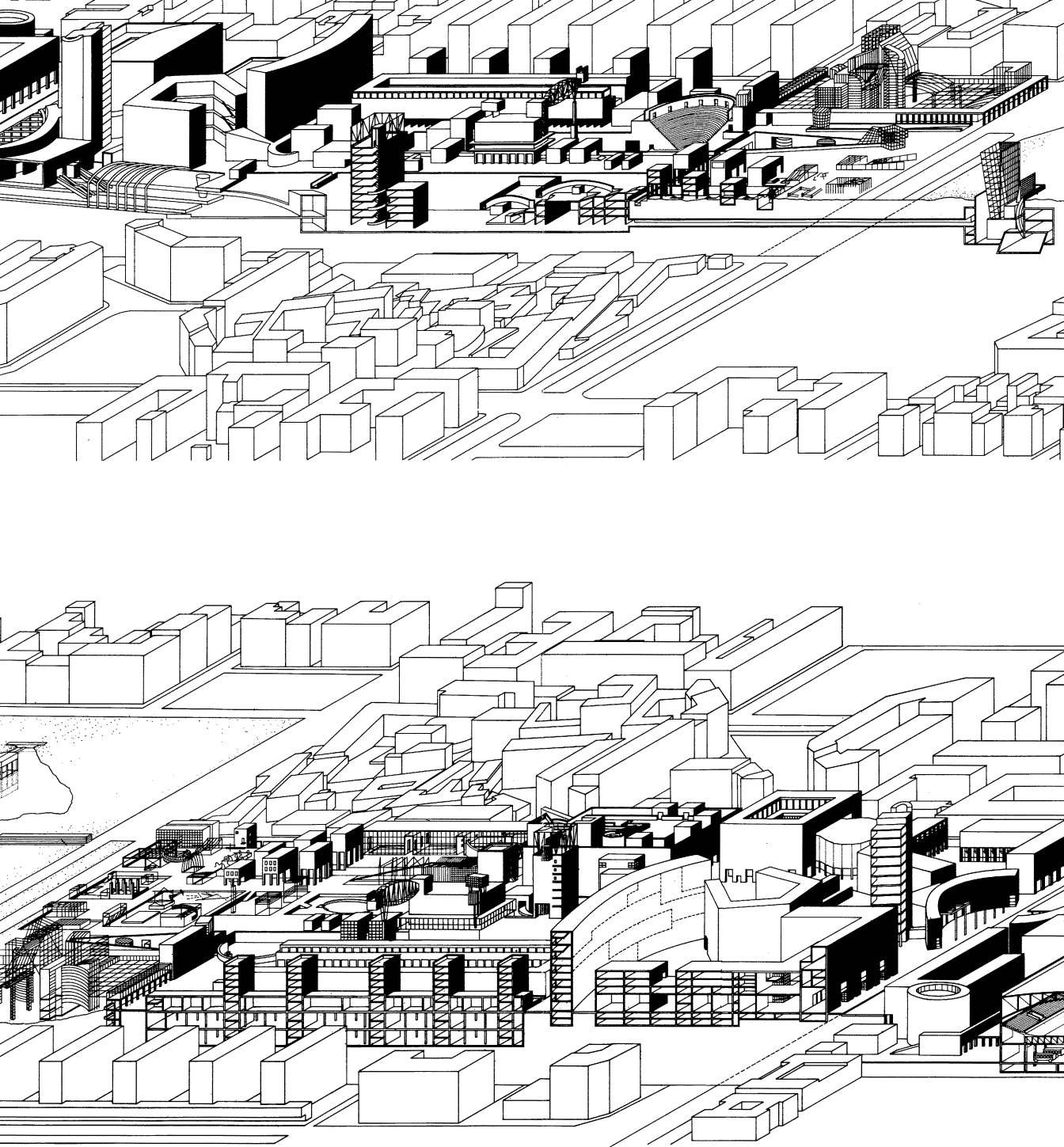
West-East Site Section



East-West Site Section

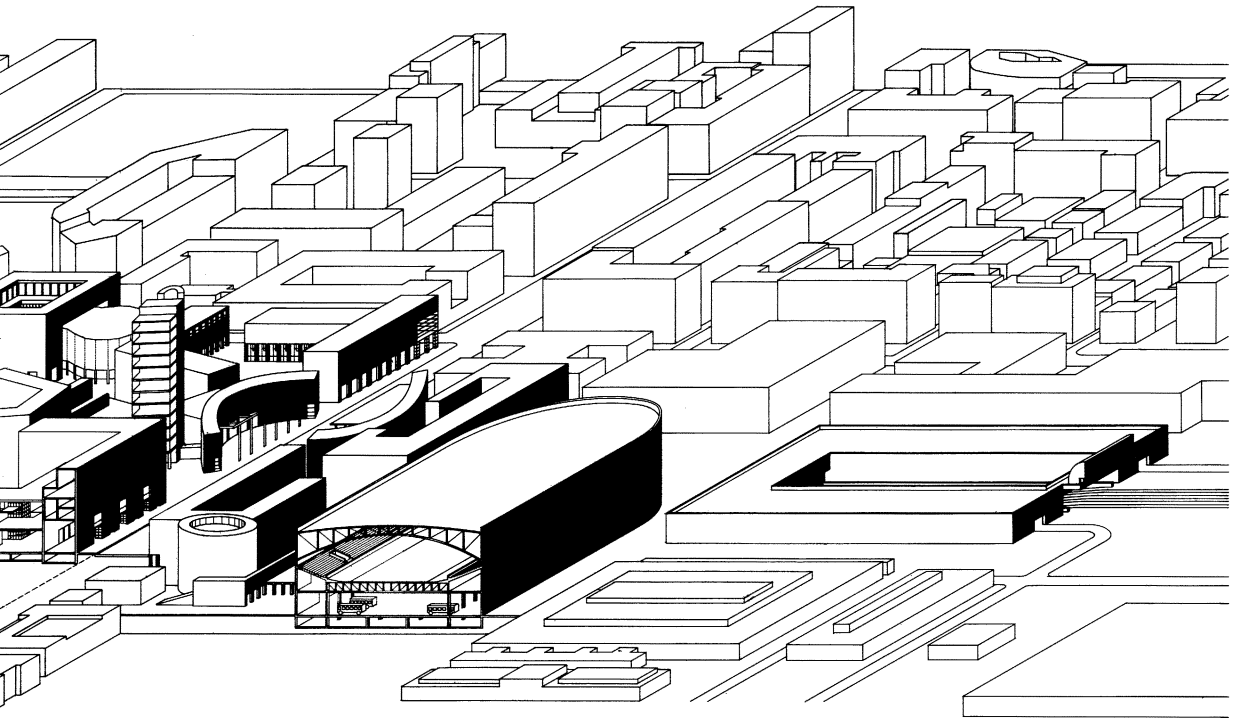
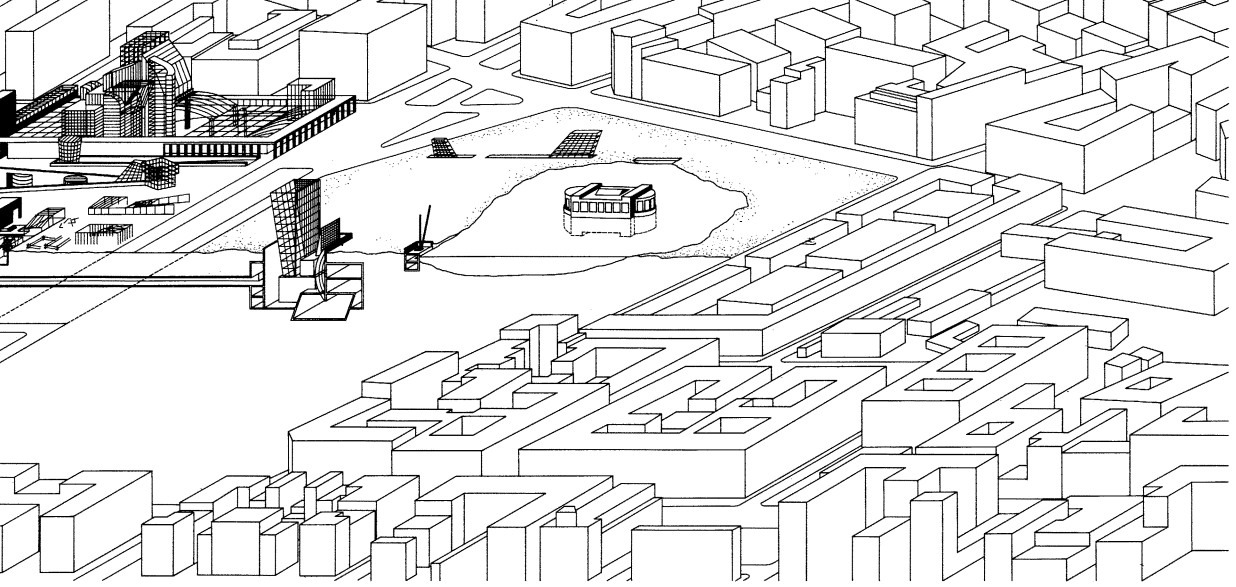
Near Via F. Rezzonico is a sanctuary of the muses filled with ancient stone. A modern cinema is inserted from the east. The public can move back and forth simulation to stone materiality.

The new subway station opens to the west onto an elongated gap. Here the through several activities, rising through an elliptical passage to the Garden Bureaucratic and administrative activities (formless and always in flux) are urban character in a thin tower, a four-sided pentagon, a double-flux slab can be altered) and large galleries along the water basin. The three lobbies areas are connected by a central neck-shaped space.



muses filled with ancient stone fragments.
 public can move back and forth from celluloid
 onto an elongated gap. Here the visitor passes
 elliptical passage to the Garden of Sounds.
 harmless and always in flux) are given specific
 pentagon, a double-flux slab (whose section
 water basin. The three lobbies of these work
 l space.

Across Viale Mugello
 airport connection station
 and velodrome.
 Of these specific interventions
 intention depends on the
 of this city for which the
 to find lines of escape,
 part of projecting an overall

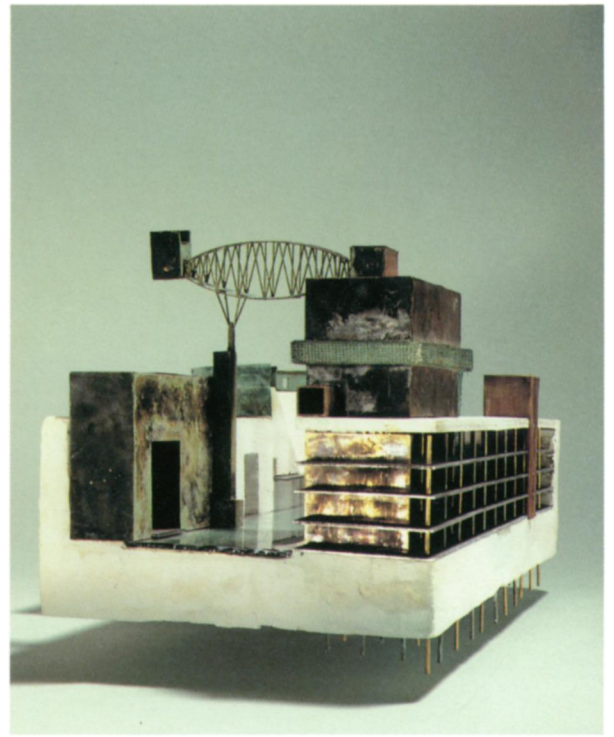


Across Viale Muguello, to the east, larger programs fit into the existing city fabric. The airport connection station sits there; adjacent is the bus garage, housed below a public arena and velodrome.

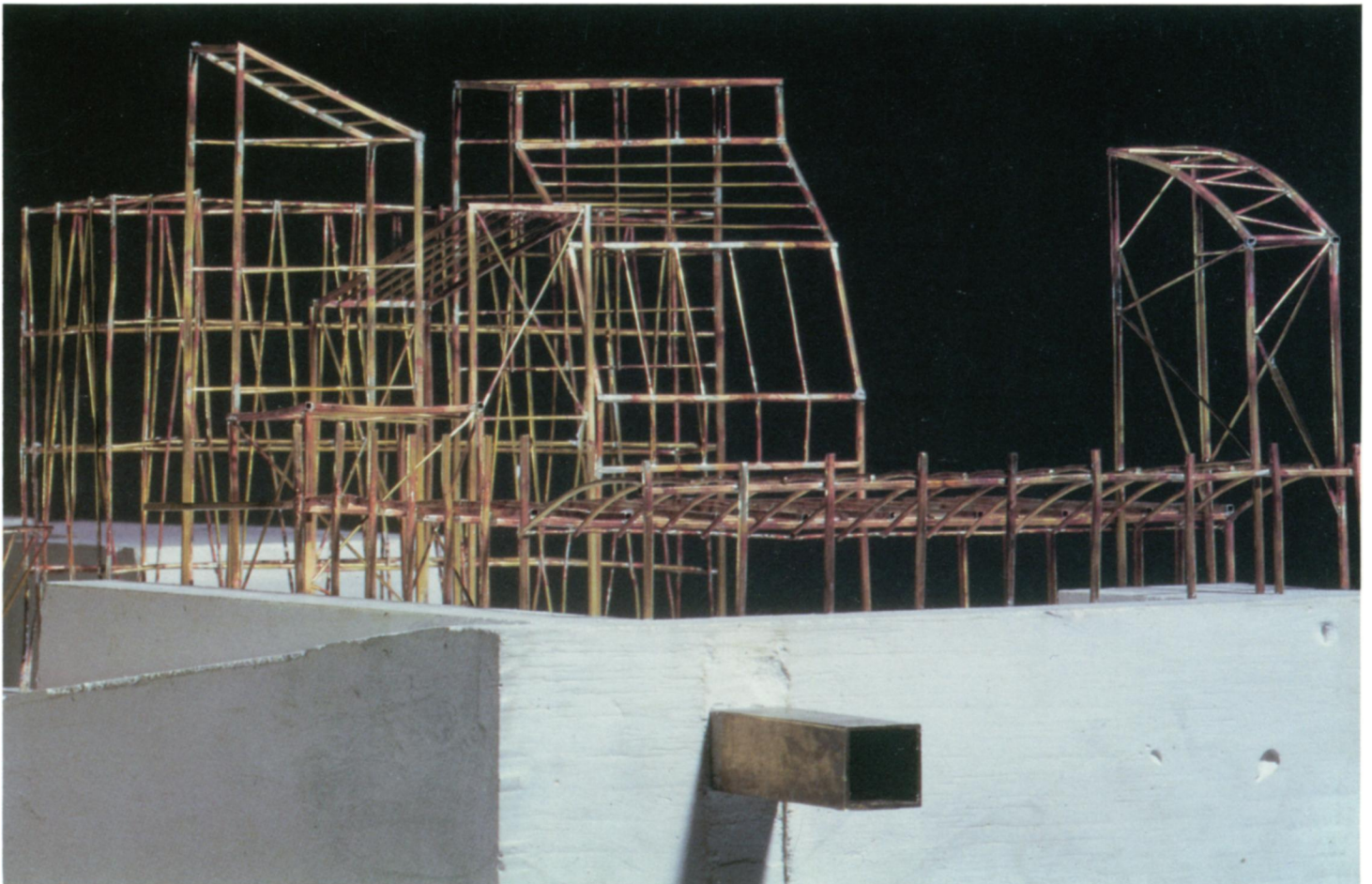
Of these specific ideas, several might be realized, and yet the overall strategy and intention depends on none of them. They serve only as examples for the figure in the landscape of this city for which the unknown is a source of optimism. To affirm the joy of the present, to find lines of escape, to subvert an overall urban plan from within—via architecture—is part of projecting an open future as a source of freedom.



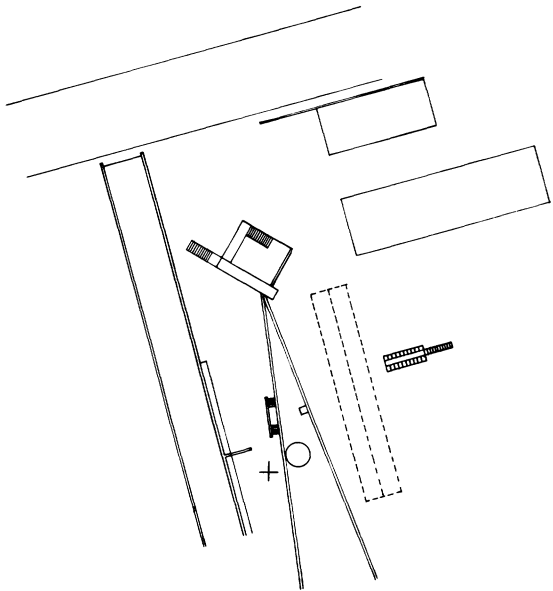
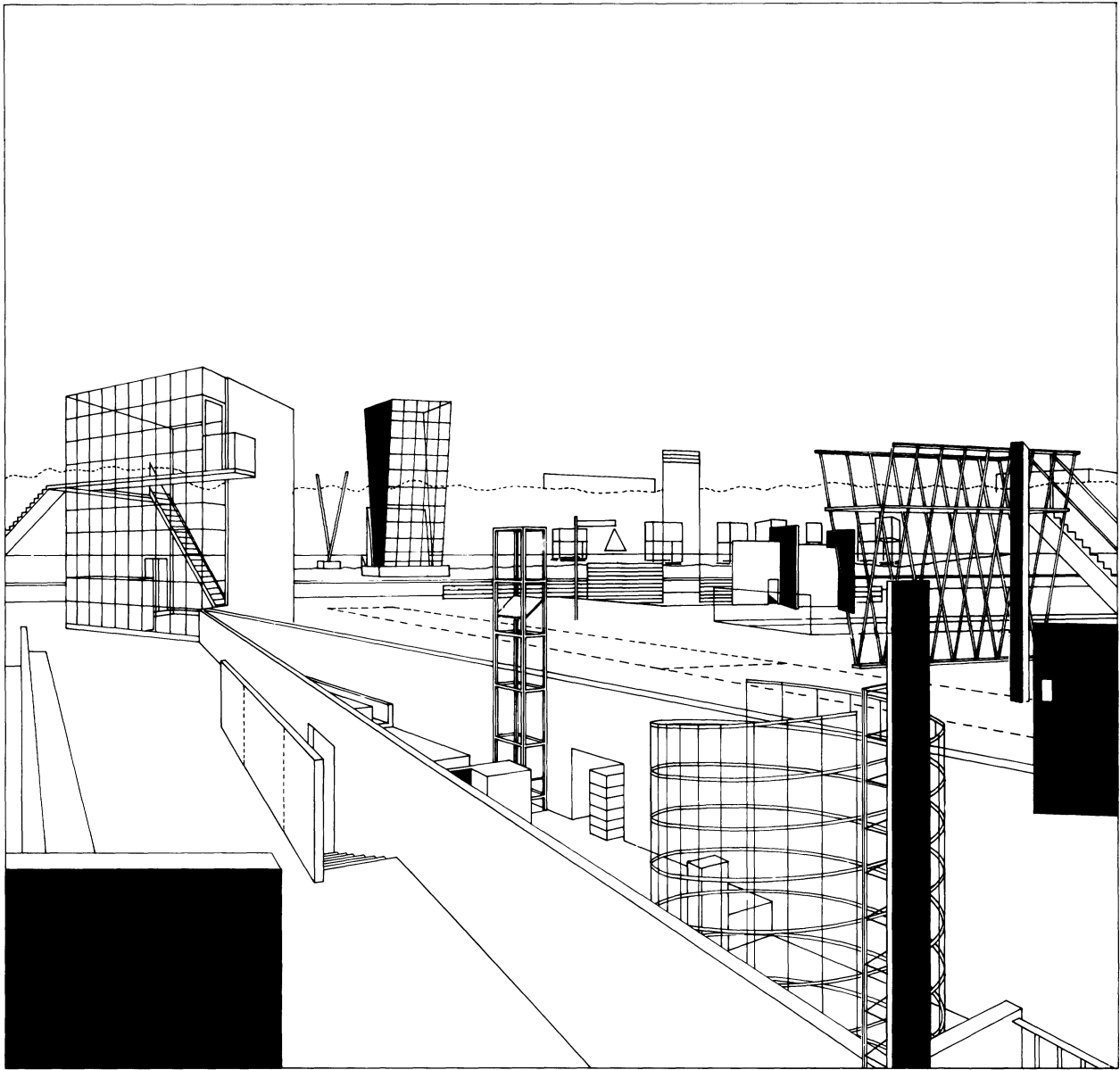
Subway Station

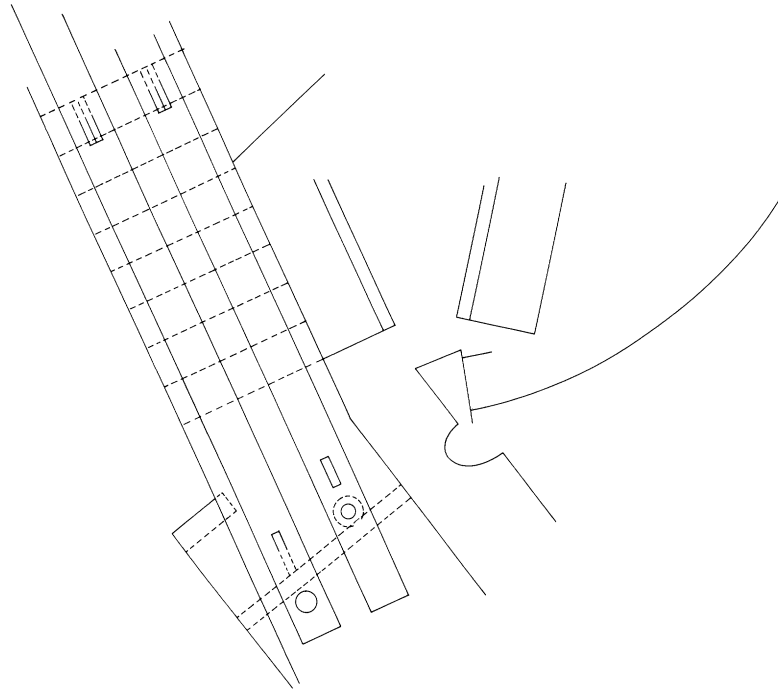
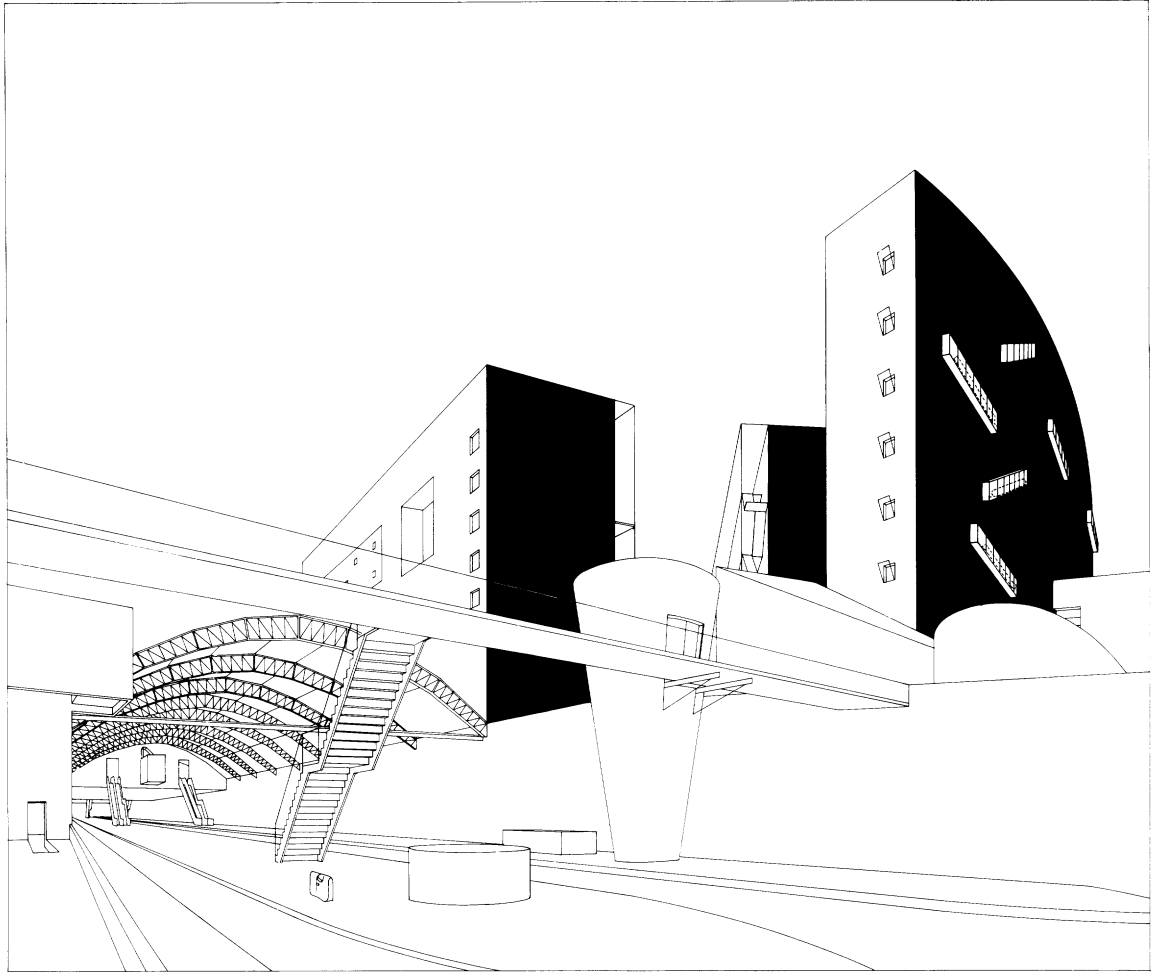


*Hotel for Unhappy
Lovers and
Psychological Bridge*

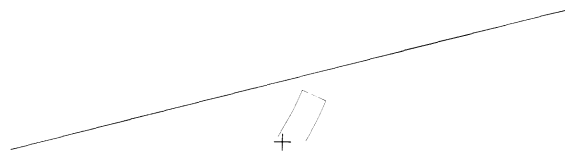
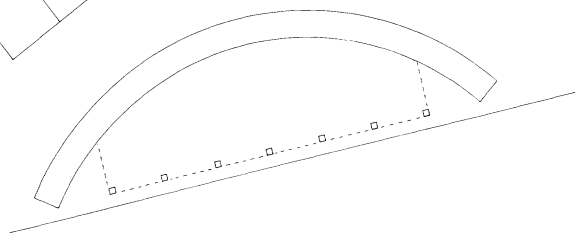
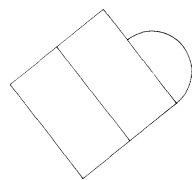
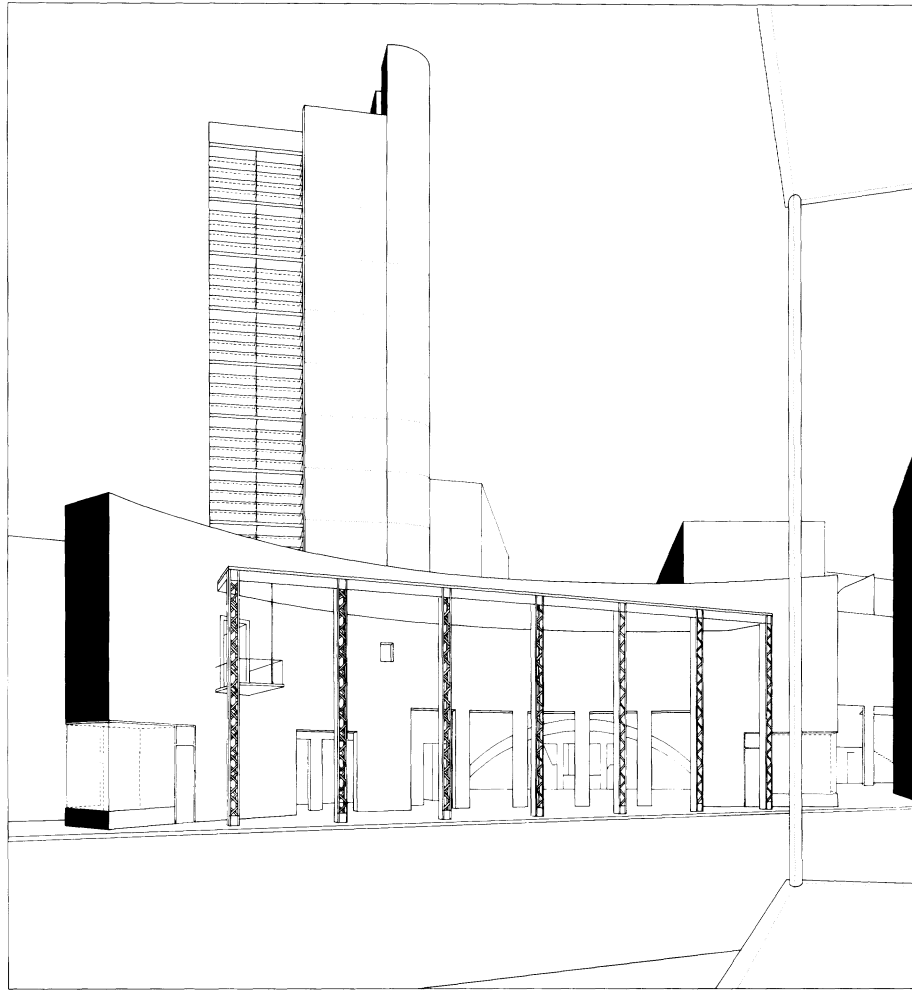


Botanical Garden

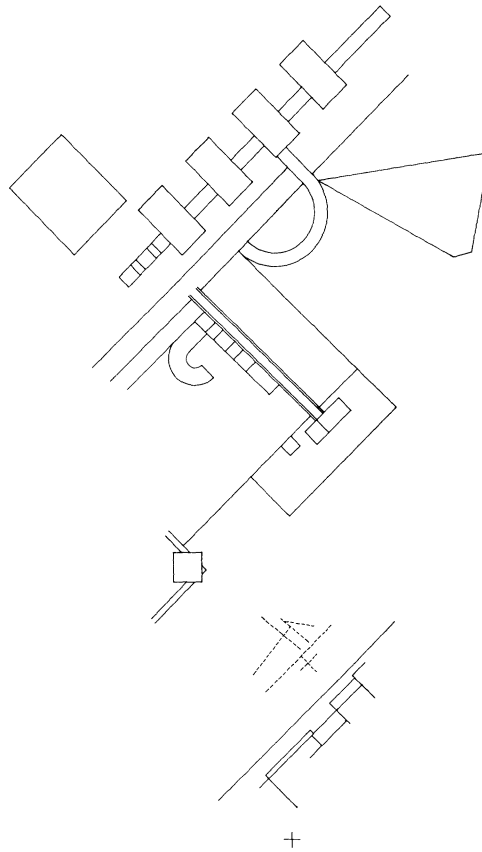
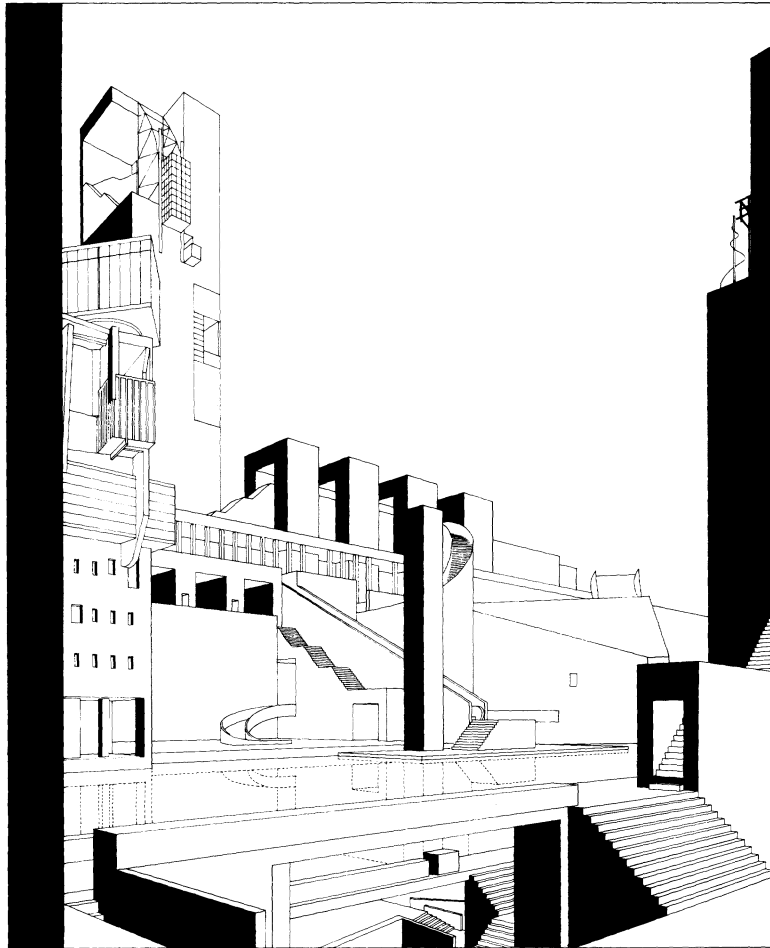




*New Subway Station
opening onto
elongated gap*



*Subway Station
and Shops;
Ticket-Taker Tower*



*Passage below
Water Basin*

*Overleaf:
Water Basin,
Amphitheater and*

L. L. D.

